

## The supposed Late Roman hoard of tools and a steelyard from Vodice near Kalce

Veronika PFLAUM

### Izvleček

Vojni muzej v Logatcu hrani skupino nestrokovno izkopanih večinoma rimskodobnih kovinskih predmetov z najdišča Vodice pri Kalcah, med njimi tudi domnevno poznorimsko zakladno najdbo kovinskih predmetov, katere sestav ni več zanesljivo znan. Podrobna opredelitev vseh predmetov je omogočila datacijo nekaterih le v rimsko cesarsko dobo, nekaterih ožje v poznorimsko dobo, štirih predmetov pa domnevno v srednji ali novi vek. Poskus rekonstrukcije na osnovi datacije predmetov, ustnih podatkov in primerjave s sočasnimi sorodnimi zakladnimi najdbami z ozemlja Slovenije je kot domnevni sestav zakladne najdbe izločil tehtnico, tri bradve, sekiri, tesli, dvostrano teslo, kopačo, rezilo za obdelavo lesa, sveder, šestilo, nakovalo, sornik in šilo. Zakladno najdbo je mogoče datirati le nenatančno v 4. st. oziroma morda na konec 4. st.

**Ključne besede:** Slovenija, Vodice pri Kalcah, poznorimsko obdobje, zakladne najdbe, orožje, orodje, nakovala, vozovi, hiposandale, tehtnice

### Abstract

The War Museum in Logatec keeps a group of unprofessionally excavated, mostly Roman metal objects from the site of Vodice near Kalce. Among them there is also a supposed late Roman hoard of metal objects, the composition of which is not definitely known any more. A detailed analysis of all objects made it possible to date some of them only to the Roman Imperial period, some more precisely to the Late Roman period and four of them assumedly to the Middle Ages or to the modern times. An attempt at reconstruction of the hoard, based on the dating of objects, oral data and comparison with similar contemporary hoards from the present-day territory of Slovenia, set apart as the supposed composition of the hoard a steelyard, three wide axes, two axes, two adzes, a double-bladed adze, a hoe, a woodworking knife, a gimlet, a pair of compasses, an anvil, a bolt, and an awl. It was possible to date the hoard only inexactly to the 4th century or maybe to the end of the 4th century.

**Keywords:** Slovenia, Vodice near Kalce, Late Roman period, hoards, weapons, tools, anvils, wagons, hipposandals, steelyards

### INTRODUCTION

The War Museum (Vojni muzej) in Logatec keeps a group of mostly Roman objects from the archaeological site Vodice near Kalce (Vodice pri Kalcah), found and excavated by an unknown unauthorized searcher of antiquities using a metal detector. The date of the discovery, the exact position and the context of the find are no longer known.\*

\* This article is a modified and complemented chapter of my thesis (Veronika Pflaum, *Late Roman 5th Century Defence and Military Traces in the Territory of the Present-Day Slovenia*, University of Ljubljana, Faculty of Arts, Department of Archaeology, Ljubljana [2004]).

According to the otherwise unreliable data of the collection-keeper Janez J. Švajncer, some of the finds almost certainly composed a late Roman hoard of metal objects. It is no longer certain, however, which objects were part of the hoard. For this reason, the whole group of finds is presented. An attempt at reconstruction of the composition of the hoard is based on the scarce oral data available, on the dating of every single object that in some cases could justify exclusion from the supposed composition of the hoard, and on comparison with similar contemporary hoards from the territory of Slovenia that could, with some probability, include or exclude some objects from the composition of the hoard.



Fig. 1: The view from Vodice in the direction of Lanišče (photo V. Pflaum).

Sl. 1: Pogled z Vodice proti Lanišču (foto: V. Pflaum).

### THE ARCHAEOLOGICAL SITE VODICE NEAR KALCE

The archaeological site of Vodice near Kalce lies on the line of the Roman road connecting Logatec (*Longaticum*) with Hrušica (*Ad Pirum*), on the plain

before its ascent to Lanišče (Figs. 1; 2). In the 1980s, when a gas pipeline was being laid, numerous diverse Roman objects<sup>1</sup> and coins from the 1st to the 4th century (the latest determinable coins are from the period of issue 378-383)<sup>2</sup> were collected on the site. Later on, the site had been robbed on several occasions by unauthorized searchers of antiquities using metal detectors. The finds most probably belong to a Roman roadside post or village (*vicus*) consisting of wooden buildings, as buildings built of stone have not been discovered.<sup>3</sup>

A bit to the southwest of the site a twenty-metre section of the Roman road, at the beginning of its ascent from Vodice to Lanišče, was cleaned and documented. The road was cut into the side of the hill as a terrace; the ruts were cut into the bedrock. A silver coin of emperor Leopold I from the year 1680, found on the road, proves that the section of the Roman road passing through Vodice and Lanišče was still in use at the end of the 17th century.<sup>4</sup> A Roman milestone was found during the reconstruction work on the road in the year 1686, but both Hrušica and Vodice are mentioned as the finding place.<sup>5</sup>

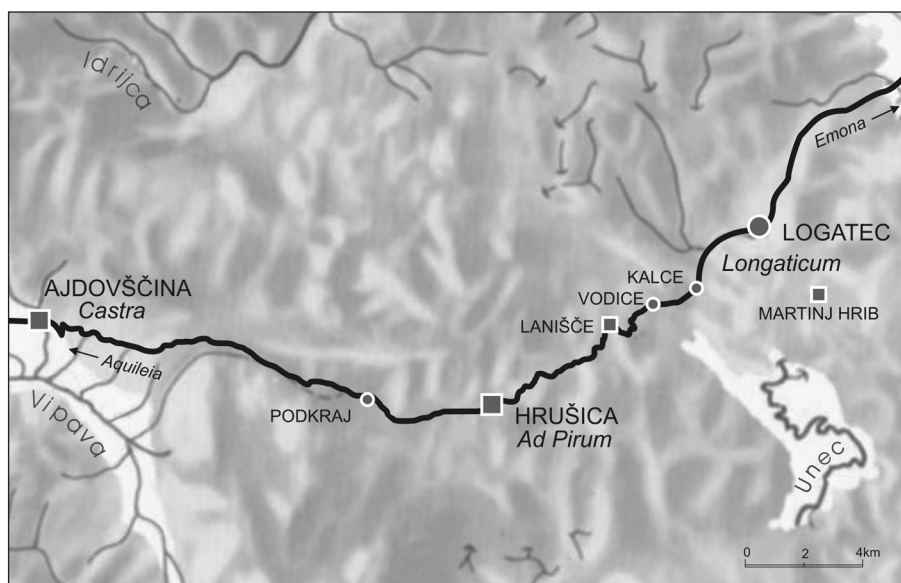

Fig. 2: The position of the archaeological site of Vodice near Kalce with regard to the line of the Roman road *Emona-Aquileia* and the near forts of the late Roman barrier system *Claustra Alpium Iuliarum*.

Sl. 2: Lega arheološkega najdišča Vodice pri Kalcah glede na potek rimske ceste *Emona-Aquileia* in bližnje utrdbe poznorimskega zapornega sistema *Claustra Alpium Iuliarum*.

<sup>1</sup> Frelih 1985; Frelih 1988, 36-40; Švajncer 2003; Pröttel 1996, 211, Taf. 21: 4,6,7 (three fragments of African sigillata plates, types Hayes 50A [dated 230-340], Hayes 59 [dated 340-420] and Hayes 61A [dated 350-410/420]).

<sup>2</sup> Kos, Šemrov 1995, 227-237, No. 95; Šemrov 1998, 213-219, No. 99.

<sup>3</sup> Frelih 1988, 36. Finds collected on the site when a gas pipeline was being laid are kept at the Institute of Archaeology,

Scientific Research Centre of the Slovenian Academy of Sciences and Arts, Ljubljana, and have not yet been published. For basic information on them and on the supposed settlement consisting of wooden buildings, I would like to thank Dr. Slavko Ciglencečki from the same institute.

<sup>4</sup> Frelih 1988, 36-39.

<sup>5</sup> *CIL* III 4614 = 15198; Sticotti 1951, 123: No. 377; Petru 1975, 123.

## CATALOGUE

All objects are kept by J. J. Švajncer in his War Museum in Logatec. As they do not have any inventory numbers, the National Museum of Slovenia (Narodni muzej Slovenije) put them on the list of finds in private property. The objects have not yet been published, except for the sword and the two pieces of its scabbard.

The objects in the catalogue are sorted into groups according to their purpose of use, irrespective of their dating: weapons (a sword, two pieces of scabbard, spearheads, two *plumbatae*), tools or kitchen implements (knives), measuring instrument (a steelyard), tools (wide axes, two axes, adzes, a hoe, a hammer, a woodworking knife, a gimlet, a pair of compasses, an anvil), horse gear and parts of wagons (hipposandals, two horseshoes, a bolt), others (an awl, a pointed object). The catalogue description of every single object includes a denotation of the object, a detailed description, measurements and weight and the number on the list of finds in private property (ZN No.).

Objects, composing the reconstructed supposed hoard, are presented in plates 1-4 at the end of the text, the others are presented in figures amid the text. Amid the text, there are also photos of the steelyard and the anvil from the hoard. The numbers of objects in the plates and figures match with the numbers of those objects in the catalogue.

1. Iron double-edged sword (*Fig. 3: 1*). The partly preserved tang is flat and rectangular in the cross-section, the shoulder is slightly slanting. The blade, lenticular in the cross-section, narrows slightly towards a relatively blunt, rounded point.

Preserved length 59.2 cm, length of the blade 56.6 cm, width of the blade up to 4.0 cm, thickness of the blade up to 0.7 cm, thickness of the tang 0.5 cm, preserved length of the tang 2.6 cm, width of the tang up to 1.7 cm, weight 528 g; ZN No. 130/2.

Bibliography: Švajncer 2003.

2. Iron disc-chape (*Figs. 3: 2; 4; 5*). The mount of a low cylindrical shape with a rectangular side-opening is decorated with inlaid brass. The motifs of the decoration are recognizable by the incisions in which the brass wire, now mostly missing, had been laid in. The front side is divided by two intersecting decorative stripes into four fields, surrounded by concentric circles on the edge. In the stripes there is a motif of continuous spirals, in the four fields there are heart-shaped leaf-motifs, and in every leaf-field there is a motif of a tendril and a trefoil. On the back side, there are leaf-motifs, arranged in a cross-shape and surrounded by concentric circles on the edge. The space in between is covered with tendrils. The side of the mount is decorated with three longitudinal lines. The round planes are slightly convex, the juncture of the front plane and the side is damaged or partly open. On the juncture of the decorated planes and the side, a thin line of solder is visible in spots. The inside of the mount is filled with an unknown organic? substance; the middle of the mount is perforated.

Diameter 6.5 cm; thickness 1.6 cm; measurements of the side-opening 4.1 × 1.0 cm; weight 86 g; ZN No. 91/4.

Bibliography: Švajncer 2003.

3. Iron scabbard slide.

The object was not available for examination, detailed description and drawing, because its keeper could not find it. ZN No. 130/2.

Bibliography: Švajncer 2003.

4. Iron spearhead (*Fig. 8: 4*). A short shaft continues into the blade, rhombic in the cross-section, forming a rib, there are two small holes in the socket, the blade reaches its maximum width by the shaft.

Length 17.1 cm, width of the blade 4.2 cm, diameter of the socket 2.35 cm, weight 186 g; ZN No. 130/16.

5. Iron spearhead (*Fig. 8: 5*). The blade is narrow, the shaft continues into the blade forming a rib, the tip of the blade is rhombic in the cross-section. At the end of a long socket there are two small holes, one of them containing a nail.

Length 21.8 cm, width of the blade 2.55 cm, diameter of the socket 2.1 cm, thickness of the blade 1.1 cm, weight 154 g; ZN No. 130/17.

6. Iron point (*Fig. 8: 6*). The point has a long point, square in the cross-section, a short shaft and an open socket, round in the cross-section, there is a small hole in the socket. The socket is partly damaged.

Preserved length 20.4 cm, diameter of the socket 1.5 cm, weight 56 g; ZN No. 130/18.

7. Iron *plumbata* (*Fig. 9: 7*). It is composed of a short iron head with a barbed tip, square in the cross-section, and of an oval leaden weight at the end of the socket. The inside of the socket is filled up with remains of the wooden shaft.

Length 10.5 cm, diameter of the leaden weight 1.6 cm, width of the tip 1.4 cm, weight 20 g; ZN No. 130/19.

8. Iron *plumbata* (*Fig. 9: 8*). It is composed of a short iron head with a barbed tip, polygonal in the cross-section, and of a leaden weight at the end of the socket. The open socket is round in the cross-section, there is a small hole in it containing a nail. The leaden weight is preserved only in traces.

Length 11.6 cm, diameter of the socket 1.2 cm, width of the tip 1.5 cm, weight 16 g; ZN No. 130/20.

9. Iron knife (*Fig. 10: 9*). The blade with a thick, bent back edge is separated from the tang by an oval arm-guard of the same width as the blade. A flat tang, rectangular in the cross-section, has a flat copper? knob at the end, the knob is partly damaged.

Length 32.4 cm, width 4.2 cm, length of the tang 10.8 cm, thickness of the back edge of the blade 1.1 cm, weight 306 g; ZN No. 130/21.

10. Iron knife (*Fig. 10: 10*). The narrow blade with a straight back edge continues into a long, narrow tang, square in the cross-section, over a slanting shoulder, the tang ends with a slightly convex knob. The tip of the blade is damaged.

Preserved length 18 cm, width 2.3 cm, weight 28 g; ZN No. 130/22.

11. Iron knife (*Fig. 10: 11*). The wide blade with a straight back edge continues into a tang, rectangular in the cross-section, over a slanting shoulder. The end of the tang is missing.

Preserved length 16 cm, width 3.4 cm, thickness 0.5 cm, weight 54 g; ZN No. 130/26.

12. Iron knife (*Fig. 10: 12*). The blade with a straight back edge continues, on the upper side, into a wide short tang, rectangular in the cross-section, over a shoulder. The tip of the blade is damaged.

Preserved length 18.1 cm, width 3.1 cm, thickness 0.7 cm, weight 60 g; ZN No. 130/27.

13. Iron knife (*Fig. 10: 13*). The leaf-shaped blade continues into a flat handle, rectangular in the cross-section, that widens towards its end.

Length 19.6 cm, width 3.2 cm, thickness 0.7 cm, weight 110 g; ZN No. 130/23.

14. Iron knife (*Fig. 10: 14*). The leaf-shaped blade continues into a flat handle, rectangular in the cross-section, that widens towards its end.

Length 17 cm, width 2.8 cm, thickness 0.6 cm, weight 74 g; ZN No. 130/24.

15. Bronze and iron steelyard with a leaden weight (*Pl. 1: 15; Fig. 11*). The bronze bar with a longer scale-arm, rhombic in the cross-section, and a shorter arm for suspending the object to be weighed, square in the cross-section, terminates at both ends with a conical knob. The right-hand knob is separated from the arm intended for suspension of the weighed object by a deep circular groove. Three circular loops are fastened through the same arm. The bronze left-hand (deformed) loop

and the right-hand loop are closed and rivetted through the bar; the iron middle loop is made out of bent wire and fastened through the bar as a split pin. In the loops there are three different suspension-hooks: the left-hand bronze hook is made out of a thin flat bent wire with thickened tip, the bottom end is bent backwards; the right-hand bronze hook is made out of bent wire, square in the cross-section, with a slightly thickened tip and the bottom end bent into an S-shape; the middle iron hook is made out of a thicker flat bent wire with a sharp tapering tip, with its end spirally wound round the bottom part of the hook. The groove between the shorter arm and the terminal knob bears a chain-suspension for the object to be weighed; the suspension is composed of an iron laterally flattened omega-shaped link, an iron U-shaped link and two chains. Each chain is composed of three links made out of a spirally twisted iron wire and a terminal link made out of a thinner bronze wire with bent ends, spirally wound round the middle of the link. A laterally flattened iron hook is preserved at the end of the first chain; a hook of the second chain is missing. The first scale, intended for the weighing of light loads, is entirely preserved and is divided into 12 units by marks in form of vertical lines (for 1-4, 6-9, 11, 12) and of characters V and X (for 5 and 10). The second scale has almost completely disappeared; it begins with the mark of double X (in place for the value 10; a later repair of the mark?), and the first V mark (for 15) is also visible, traces of the following marks are hardly visible. The third scale, for weighing of the heaviest loads, is partly visible; it begins with the XXX mark (for 30), otherwise the V and X marks alternate for the fives and tens. A leaden spherical weight is suspended on the scale-arm by a laterally flattened iron hook.

Length of the bar 29.6 cm, length of the scale-arm without the knob 19.4 cm, thickness of the scale-arm 0.8 cm, length of the arm for suspending the object to be weighed without the knob 8.2 cm, thickness of this arm 1.0 cm, distance between the beginning of this arm and the centre of the left-hand loop 0.8 cm, distance between the centre of the left-hand loop and the centre of the middle loop 4.4 cm, distance between the centre of the middle loop and the centre of the right-hand loop 1.9 cm, distance between the centre of the right-hand loop and the groove 1.1 cm, distance between the first mark on the first scale and the middle of the left-hand loop 2.4 cm, distance between the first mark on the second scale and the middle of the middle loop 5.7 cm, distance between the first mark on the third scale and the middle of the right-hand loop 7.7 cm, distance between the first and the last mark on the first scale 16.7 cm, distance between the first and the last mark on the third scale 19.3 cm, length of the first scale 18.2 cm, length of the third scale 19.3 cm, length of the chain-suspension 44 cm, diameter of the leaden weight 6.6 cm, length of the weight with the hook 15.7 cm, weight of the weight with the hook 1486 g, weight of the steelyard without the weight 296 g, total weight 1792 g. The chain-suspension has not been weighed because it was not possible to take it off from the bar and because it is not entirely preserved. ZN No. 91/1.

16. Iron wide axe (*Pl. 2: 16*). The head has an oval hafting hole, reinforced by low rectangular side pieces on both sides. Pieces of wooden helve are preserved in the hafting hole.

Height 14 cm, width 9.5 cm, thickness 3.55 cm, weight 594 g; ZN No. 130/34.

17. Iron wide axe (*Pl. 2: 17*). The back of the head is slightly extended, the head has an oval hafting hole, reinforced by low rectangular side pieces on both sides.

Height 18.4 cm, width 16.4 cm, thickness 3.9 cm, weight 1094 g; ZN No. 130/35.

18. Iron wide axe (*Pl. 2: 18*). The low head has a hafting hole of a rectangular form with rounded off corners.

Height 14.4 cm, width 14.2 cm, thickness 3.4 cm, weight 556 g; ZN No. 130/33.

19. Iron axe (*Pl. 2: 19*). The elongated back of the head terminates with four small tines. The blade widens symmetrically towards the cutting edge, there are traces of wooden helve preserved in the oval hafting hole.

Height 13.6 cm, length of the back of the head 10.8 cm, thickness 2.0 cm, weight 390 g; ZN No. 130/31.

20. Iron axe (*Pl. 2: 20*). The back of the head is elongated, the narrow blade widens asymmetrically downwards. There are traces of wooden helve preserved in the oval hafting hole.

Height 21 cm, length of the back of the head 11.2 cm, thickness 3.8 cm, weight 1214 g; ZN No. 130/32.

21. Iron adze (*Pl. 3: 21*). The adze has a curving blade and a short, hammer-like extension on the back of the head; the head has an oval hafting hole, reinforced by hardly visible side pieces on both sides.

Height 16.5 cm, width of the blade 6 cm, measurements of the back of the head 3.5 × 3.6 cm, weight 556 g; ZN No. 130/29.

22. Iron adze (*Pl. 3: 22*). The adze has a curving blade and a short, hammer-like extension on the back of the head; the head has an oval hafting hole, reinforced by low side pieces on both sides.

Height 21.3 cm, width of the blade 7.8 cm, measurements of the back of the head 3.2 × 4.1 cm, weight 914 g; ZN No. 130/28.

23. Iron double-bladed adze (*Pl. 3: 23*). The first blade is formed like an adze, the second blade has downwards-bent sides at the end.

Height 23.7 cm, width 5.3 cm, weight 404 g; ZN No. 130/30.

24. Iron hoe (*Pl. 3: 24*). The hoe has a wide triangular blade and straight prongs, square in the cross-section. The head has an oval hafting hole, reinforced by side pieces on both sides.

Height 23.8 cm, width 12.2 cm, weight 660 g; ZN No. 130/25.

25. Iron claw hammer (*Fig. 12: 25*). One end of the head is round, at the other end there is a claw with one straight and one triangular tip. The head has a rectangular hafting hole with rounded off corners, reinforced by two side pieces; in the hole, there is a rest of a band with an enlarged head.

Height 14 cm, width 4.1 cm, thickness 3.0 cm, diameter of the round end of the head 2.3 cm, weight 186 g; ZN No. 130/12.

26. Flat iron nail (*Fig. 12: 26*), rectangular in the cross-section, with a narrow rectangular head, a part of the nail is broken off.

Length 7.45 cm; ZN No. 130/12.

27. Iron nail (*Fig. 12: 27*), square in the cross-section, with a square head, bent, a part of the nail is broken off.

Length 3.15 cm; weight of the two nails together 8 g; ZN No. 130/12.

28. Iron woodworking knife (*Pl. 3: 28*). The blade is curved at the end with a tang, rectangular in the cross-section, set at a right angle to the blade. At the other end the blade continues into a flat extension, terminating with a loop.

Length 46 cm, width of the blade 4.5 cm, thickness 1.3 cm, weight 726 g; ZN No. 130/15.

29. Iron gimlet with a spoon bit (*Pl. 4: 29*). The shank is round in the cross-section, the flat, narrow, leaf-shaped pointed tang is rectangular in the cross-section.

Length 31.4 cm, width of the spoon bit 2.2 cm, width of the tang 2 cm, diameter of the shank 1.1 cm, weight 164 g; ZN No. 130/11.

30. Iron pair of compasses (*Pl. 4: 30*). The legs, rectangular in the cross-section, with flat semicircular plates at the top, are joined together by a pin, which is flattened on one side and hammered into a low convex head on the other side.

Length 36.4 cm, width of the plates 3.6 cm, thickness 2.1 cm, weight 438 g; ZN No. 130/10.

31. Iron anvil (*Pl. 4: 31; Fig. 13*). The cubiform anvil has a slightly convex and extended upper surface. The bottom face is slightly vaulted, its edges are curved inwards and obliquely cut, shaping the lower corners of the anvil into low pointed small legs, triangular in the cross-section.

Measurements of the upper surface 21 × 22 cm, height 20 cm, weight 50 kg; ZN No. 130/1.

32. Iron hipposandal (*Fig. 14: 32*). A long vertical flat front neck, rectangular in the cross-section, ends with a narrower external loop, square in the cross-section. The boot has curved side wings, four pyramidal spikes on the sole and a lifted rear hook, rectangular in the cross-section.

Length 20 cm, width 12 cm, height 12 cm, weight 570 g; ZN No. 130/4.

33. Iron hipposandal (*Fig. 14: 33*). A long vertical flat front neck, rectangular in the cross-section, ends with a narrower external loop, square in the cross-section. The boot has curved side wings, four pyramidal spikes on the sole and a slightly lifted rear hook, square in the cross-section. Wings and the rear of the sole are partly damaged.

Length 19 cm, width 13.2 cm, height 10 cm, weight 628 g; ZN No. 130/6.

34. Iron hipposandal (*Fig. 15: 34*). A long vertical flat front neck, rectangular in the cross-section, ending with a narrower external loop, now missing. The boot has curved side wings, four pyramidal spikes on the sole and a lifted rear hook, square in the cross-section. On the bottom face of the sole, in front, there are three parallel longitudinal grooves, reaching almost to the middle of the sole. By the spikes, below the wings, there are short parallel transverse grooves in pairs. Wings and the rear of the sole are partly damaged.

Length 17.4 cm, width 10.7 cm, height 12.3 cm, weight 490 g; ZN No. 130/5.

35. Iron hipposandal (*Fig. 15: 35*). A long vertical flat front neck, rectangular in the cross-section, ends with a narrower external loop, square in the cross-section. The boot has curved side wings, four pyramidal spikes on the sole and a slightly lifted rear hook, square in the cross-section. Wings are partly damaged.

Length 21.7 cm, width 14.45 cm, height 9.75 cm, weight 480 g; ZN No. 130/7.

36. Iron hipposandal (*Fig. 15: 36*). A long vertical flat front neck, rectangular in the cross-section, ends with a big narrower external loop, rectangular in the cross-section. The boot has curved side wings and three pyramidal spikes on the sole. The rear of the sole with the fourth spike and the hook are missing.

Preserved length 14.7 cm, width 13.3 cm, height 10.35 cm, weight 652 g; ZN No. 130/3.

37. Iron horseshoe (*Fig. 16: 37*). The horseshoe is thin and wide, the outer edge is slightly lifted, the crescent-shaped shanks narrow equably towards the end. On the edge of each shank there is a shallow groove with four rectangular holes for the nails. Two nails, rectangular in the cross-section, with an oblong rectangular convex head are preserved. The ends of the shanks are damaged.

Preserved length 11.5 cm, width 10.8 cm, thickness 0.6 cm, weight 116 g; ZN No. 130/8.

38. Iron horseshoe (*Fig. 16: 38*). The horseshoe is thin and wide, there is a rib on the outer edge, the crescent-shaped shanks narrow equably towards the end. On the edge of each shank there is a shallow groove with four rectangular holes for the nails. A nail, rectangular in the cross-section, with an oblong rectangular convex head is preserved. A piece of one shank is missing.

Length 10.5 cm, width 10.2 cm, thickness 0.65 cm, weight 96 g; ZN No. 130/9.

39. Iron bolt (*Pl. 4: 39*). The long cylindrical stem ends with a flat rectangular head that is partly damaged. The other

end of the stem is hollow, there is a lateral hole of an irregular rectangular shape.

Length 62.3 cm, diameter 2.8 cm, measurements of the head 3.7 × 8.3 cm, weight 2462 g; ZN No. 130/37.

40. Iron awl (*Pl. 4: 40*). The awl, square in the cross-section, tapering towards the pointed end, has a flattened top, rectangular in the cross-section, curved into an open loop.

Length 16 cm, width 1.4 cm, weight 24 g; ZN No. 130/13.

41. Iron object (*Fig. 18*). The pointed object, rectangular in the cross-section with faceted edges, tapering towards a curved tip, round in the cross-section, has a short, narrower tang, irregularly square in the cross-section.

Length (bent) 9.9 cm, width 1.1 cm, weight 24 g; ZN No. 130/14.

#### The objects from the reconstructed supposed hoard

Plate 1: cat. no. 15.

Plate 2: cat. nos. 16-20.

Plate 3: cat. nos. 21-24, 28.

Plate 4: cat. nos. 29-31, 39, 40.

### CLASSIFICATION OF THE FINDS

#### Weapons

##### *Sword and two pieces of its scabbard*

The iron double-edged sword from Vodice (*Fig. 3: 1*) belongs to the group of Roman long swords (*spathae*), often analysed in detail,<sup>6</sup> but none of the defined types or individual finds matches the sword from Vodice in all the details of shape and measurements. The comparison is also made difficult by the fact that the sword from Vodice is partly damaged; that is why only a general ascertainment of the formal and chronological development of swords of such kind, based mainly upon research of the Roman swords found in Barbaricum - as swords are rarely found on Roman territory - could be of some help.

Günter Ulbert has, on the basis of the length-to-width ratio of the blade, divided the Roman long swords of the 3rd century into two contemporary types (a short wide type and a narrow long type): the Lauriacum-Hromówka type (width of the blade 6.2-7.5 cm, ratio of length to width 8-12 : 1) and the Straubing-Nydam type (width of the blade up to 4.6 cm, ratio of length to width 15-17 : 1).<sup>7</sup> The sword from Vodice does not match either of the two types completely; according to the width of the blade (4.0 cm) it could be classified as Straubing-

<sup>6</sup> Ulbert 1974; Schulze-Dörrlamm 1985; Lønstrup 1986; Kaczanowski 1992; Biborski 1994; Rald 1994; Ilkjær 1994; also Bishop, Coulston 1993, 69-74, 126, 162; Feugère 1993, 147-150, 246; Menghin 1983, 15-16.

<sup>7</sup> Ulbert 1974, 199-204.

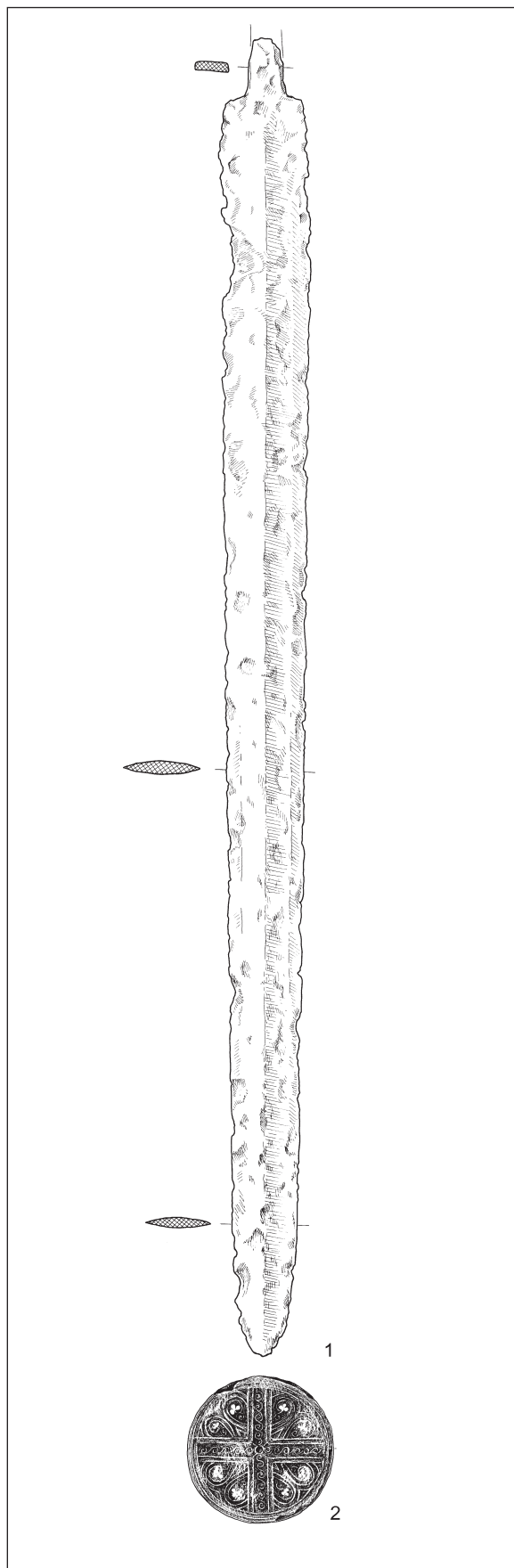

Fig. 3: The sword (1) and the chape (2) from Vodice. 1 iron, 2 iron, brass. Scale = 1:3.

Sl. 3: Meč (1) in zaključek nožnice meča (2) z Vodice. 1 železo, 2 železo, medenina. M. = 1:3.

Nydam type, but because of the shortness of the blade (56.6 cm) the length-to-width ratio of the blade (14.15 : 1) lies between the two groups, yet again closer to the Straubing-Nydam type.

The swords of the 3rd century and of the Late Roman period, matching the sword from Vodice in measurements but not necessarily in formal details, were denominated by Piotr Kaczanowski as the Augst type.<sup>8</sup> Their blades are 55 to 60 cm long and about 4 cm wide, which completely matches the measurements of the sword from Vodice. He mentions only four finds; the one that was found in Augst is dated to the 3rd century.

Roman double-edged long swords or *spathae* appear mostly from the 3rd century onwards. It is not possible to make out the chronological development of the swords and therefore not to date them only on the basis of their length. The length (as well as the width) of the blades does grow with time, but only from the 4th century onwards.<sup>9</sup> A certain connection between the length of blades and the dating was noticed by Jørgen Ilkjær on the Danish bog site Illerup Ådal. The swords from the place, where the deposits of objects A and B overlapped (deposit A is dated to the years around 200 AD, deposit B after 200 AD), had blades 61.5 to 78.0 cm long. On the other hand, the swords from deposit place C, dated to the years around 400 AD or a little earlier, had blades 76.5 to 85.5 cm long. Evident differences between the swords of the first (deposits A and B) and the second (deposit C) group, clearly dated to different periods, were also noticed in the length of the tang and the shape of the blade in the cross-section, but these statements are of no significance for the sword from Vodice, as its tang is missing and there is no blade, lenticular in the cross-section, amongst the Danish swords.<sup>10</sup> The blade of the sword from Vodice is shorter than the blades of swords from both Danish groups, but it is still closer to the first group, dated to the beginning or the first quarter of the 3rd century. Studying the same swords, Jørn Lønstrup noticed that the cutting edges of the blades of the swords of the older group converge more markedly, while the edges of the blades of the younger group run

<sup>8</sup> Kaczanowski 1992, 30, rys. 3: 1-4.

<sup>9</sup> Feugère 1993, 147-148; Menghin 1983, 16.

<sup>10</sup> Ilkjær 1994, 236, 239.

almost parallel to each other.<sup>11</sup> The blade of the sword from Vodice, narrowing from 4 cm at the top to 3 cm before the tip, would probably correspond to the swords of the older group from the Danish site. However, it has not yet been verified if the statements about the swords from the site Illerup Ådal could be generalized for all similar Roman swords.

Mechthild Schulze-Dörrlamm observed the width of the blades of swords in well-dated Germanic graves of the late 3rd and 4th centuries.<sup>12</sup> She found that swords with a very narrow blade (3.0 to 4.4 cm) were older than swords with a blade wider than 4.5 cm. The studied swords with very narrow blades were in use in the late 3rd century and in the first half of the 4th century, but they already disappeared in the second half of that century. The sword from Vodice matches her group of swords with a very narrow blade, its blade being 4 cm wide.

The search for similar swords that could help classify the sword from Vodice is questionable; none of the swords matches it in all the details

and it is not known which of the formal details and measurements are really important or more important than others for dating and classifying a sword. Nevertheless, we can list some similar swords, mostly found on the Roman territory.

A sword of almost the same shape, only longer, was excavated in *Carnuntum*; the date and the context of the find are unknown.<sup>13</sup> It is one of the few swords with blades, lenticular in the cross-section, like the one from Vodice. A similar, but smaller sword found in a grave on the site of Alzey, dated to the late 3rd and early 4th century, also has a blade, lenticular in the cross-section.<sup>14</sup> A sword resembling the sword from Vodice in size and form (the shape of the tip, the shoulder, the blade in the cross-section) had also been found in Belgium, on the site of Liberchies. It is dated to the first quarter of the 3rd century.<sup>15</sup> It is distinguished from the sword from Vodice by a longer blade and its stronger tapering.

Four similar swords, dated to the 3rd century and classified into the Straubing-Nydam type of

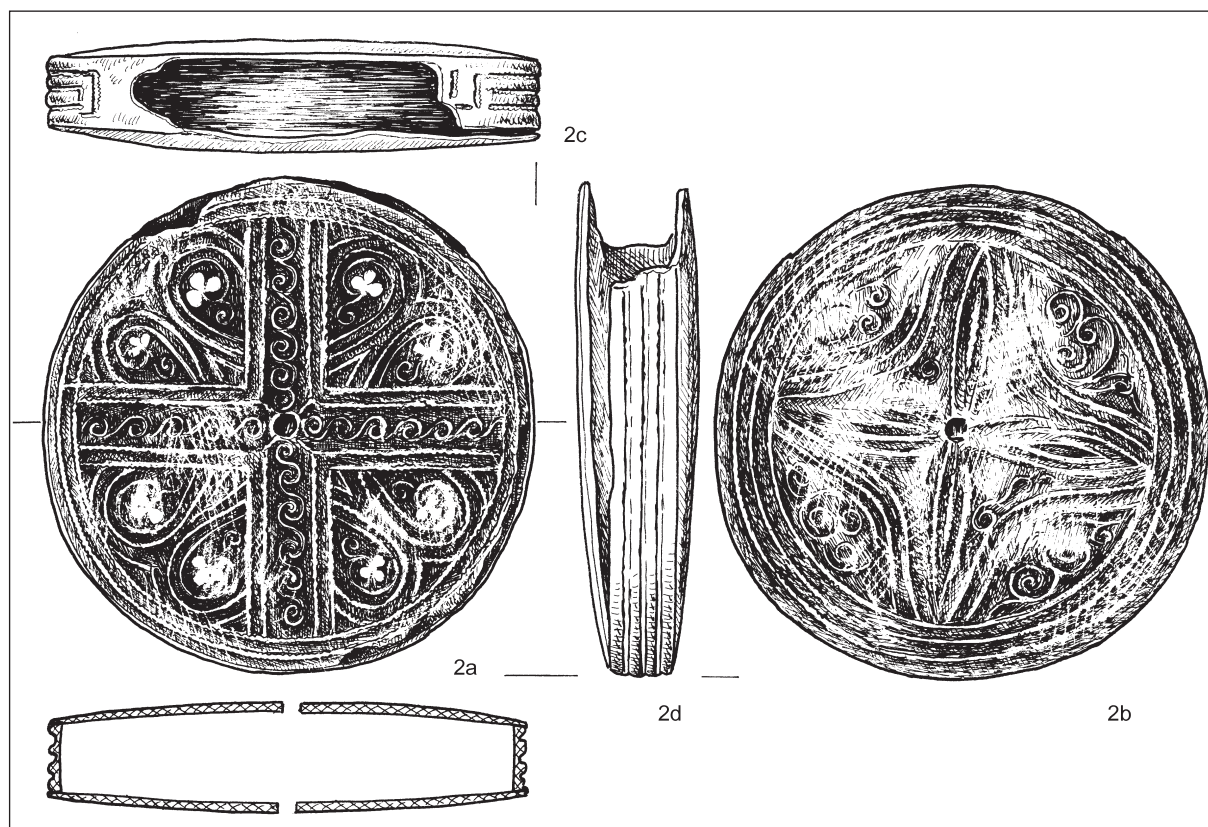

Fig. 4: The chape (2) from Vodice. Iron, brass. Scale = 1:1.

Sl. 4: Zaključek nožnice meča (2) z Vodice. Železo, medenina. M. = 1:1.

<sup>11</sup> Lønstrup 1986, 748.

<sup>12</sup> Schulze-Dörrlamm 1985, 542 note 31, Tab. 1. On width of blades of swords and on width in proportion to length of blades also Künzl 1993.

<sup>13</sup> Ponstingl 1986, 273, Abb. 32.

<sup>14</sup> Schulze-Dörrlamm 1985, 511 No. 2, 542, Abb. 3: 1.

<sup>15</sup> Berghe 1996, 80, Fig. 12: 3.

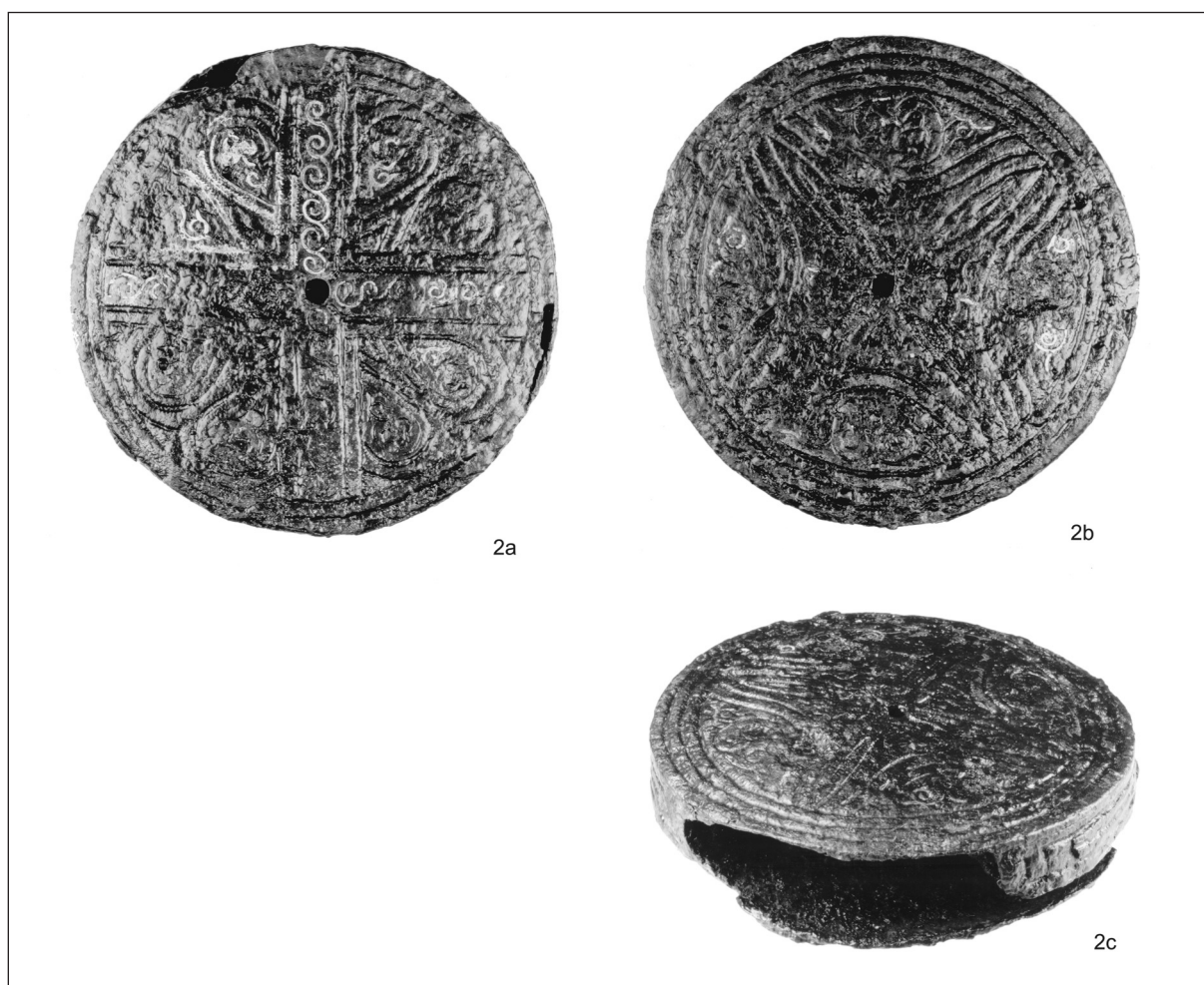

Fig. 5: The front (2a) and back side (2b) and the side view (2c) of the chape from Vodice. Scale = 1:1 (photo T. Lauko, NMS).  
 Sl. 5: Prednja (2a) in zadnja stran (2b) ter stranski pogled (2c) zaključka nožnice meča z Vodice. M. = 1:1 (foto: T. Lauko, NMS).

swords, defined by G. Ulbert, were excavated in Augst.<sup>16</sup> They vary from the sword from Vodice first of all in the blade, faceted in the cross-section.

On the basis of general statements about Roman double-edged long swords and of individual similar swords, we can date the sword from Vodice to the 3rd century. According to the two typological classifications, we could classify it conditionally into the Straubing-Nydam type, as defined by G. Ulbert, or to the Augst type, as defined by P. Kaczanowski, both typical types of the 3rd century.

Two pieces of scabbard have been found together with the sword in their original position - an iron scabbard slide (*cat. no. 3*), used for suspending the scabbard on a baldric, and an iron chape, formed as a flat round case, with inlaid brass decoration (*Figs. 3: 2; 4; 5*). Such chapes were normally an

ornament on scabbards of long narrow swords of mainly the 3rd century. In addition to the iron chapes with inlaid metal decoration, which are the most frequent, chapes made of niello-inlaid silver, bronze and ivory are also known.<sup>17</sup> Occasionally, swords with round chapes are also represented on tombstones as part of the military equipment.<sup>18</sup> In Slovenia, such a military tombstone is built into the southern exterior wall of the small church of Saint Nicholas (sv. Miklavž) in Vrba above Dobrna near Celje (*Fig. 6*).<sup>19</sup> The tombstone was discovered in 1890 in the pavement of the church. Above the inscription field, the deceased Aurelius Victor is represented wearing a short tunic with a wide belt

<sup>17</sup> *Ib.*, 158-159.

<sup>18</sup> *Ib.*, 158 note 19, Abb. 7.

<sup>19</sup> *CIL* III 11700; Saria 1924, 251, 252, Abb. 2; Hoffiller, Saria 1938, 7: No. 10; Petrovitsch 2006, 206-207, with further bibliography. I would like to thank Dr. Dragan Božič for pointing the tombstone out to me.

<sup>16</sup> Martin-Kilcher 1985, 174 No. 2, Abb. 21: 1, 183 Nos. 19, 20, Abb. 25: 2,3, 190 No. 45, Abb. 25: 4.





Fig. 6: Tombstone of Aurelius Victor from Vrba above Dobrna near Celje, where a big round chape can be clearly seen (photo M. Pflaum).

Sl. 6: Nagrobnik Avrelija Viktorja, vzdian v cerkvico sv. Miklavža v Vrbi nad Dobrno pri Celju, na katerem je lepo viden velik okrogel zaključek nožnice meča (foto: M. Pflaum).

and a cape, fastened on the right shoulder, with his complete military equipment: an oval shield, a spear and a long sword with a big round chape. He was a soldier of the *legio II Italica* and was missing, aged 30, in a war against the Goths. The tombstone has been dated to the middle or the second half of the 3rd century on the basis of the style of the inscription, and on the basis of the soldier's costume.<sup>20</sup>

<sup>20</sup> Hoffiller, Saria 1938, 7: No. 10; Petrovitsch 2006, 206.

The archaeological finds of the round chapes have already been the subject of exhaustive studies and overviews,<sup>21</sup> therefore only a brief summary follows of the findings, important for the find from Vodice. Iron chapes with inlaid metal decoration are known from sites along the Germanic *limes* and in the *Barbaricum*,<sup>22</sup> so far, finds elsewhere (e.g., Vodice) have been exceptions.<sup>23</sup> Two groups were described regarding the way of arranging the decorative motifs. In the first group, the motifs are arranged axially symmetrically along the longitudinal axes, crosswise or in sectors of a quarter of a circle. The main motifs are simple tendrils with leaves, a continuous spiral and sometimes a rosette in the middle. The diameter of the chapes of the first group lies somewhere between 6.4 and 7.2 cm. In the second group, the motifs are arranged in several concentric rings and at least partly designed by use of a pair of compasses. Chapes with such an arrangement of motifs are bigger, their diameter lies between 8.5 and 9.6 cm. The two groups also differ in the form of the chapes: smaller chapes, bearing the decoration of the first group, have flat or slightly convex round planes; bigger chapes, bearing the decoration of the second group, have, as a rule, a flat back plane and a convex front plane with a conic embossment or a concavity in the middle. There are no final datings of the two groups. The chapes of the second group supposedly date to the second half of the 3rd century, however, the chapes of the first group also appear in the second half of the 3rd century.<sup>24</sup> The chape from Vodice, with its motifs, their arrangement, its diameter of 6.5 cm and its slightly convex round planes completely corresponds to the first group of chapes.

In spite of an equal selection of motifs and common traits in the design of the decoration, every chape is unique, decorated in a slightly different way. Therefore we can find parallels to the decoration of the chape from Vodice for the separate decorative fields and not for the decoration of the front or of the back side as a whole. The heart-shaped fields with the motif of a tendril and a trefoil, such as those on the front side of the chape from Vodice, are also found on the chape from the fort at Zugmantel (Fig. 7: a),<sup>25</sup>

<sup>21</sup> Hundt 1953; Hundt 1955; an overview, with older bibliography Martin-Kilcher 1985, 150-164, Abb. 3-12; Oldenstein 1976, 116, Taf. 22-24; Borhy 1989; Kaczanowski 1992, 47-48, rys. 12; Bishop, Coulston 1993, 130; Lenz-Bernhard 1986.

<sup>22</sup> Martin-Kilcher 1985, 159; Kaczanowski 1992, 47, 91, zast. 9.

<sup>23</sup> Borhy 1989.

<sup>24</sup> Martin-Kilcher 1985, 159.

<sup>25</sup> Hundt 1953, 66, Abb. 1: 2a; 4.

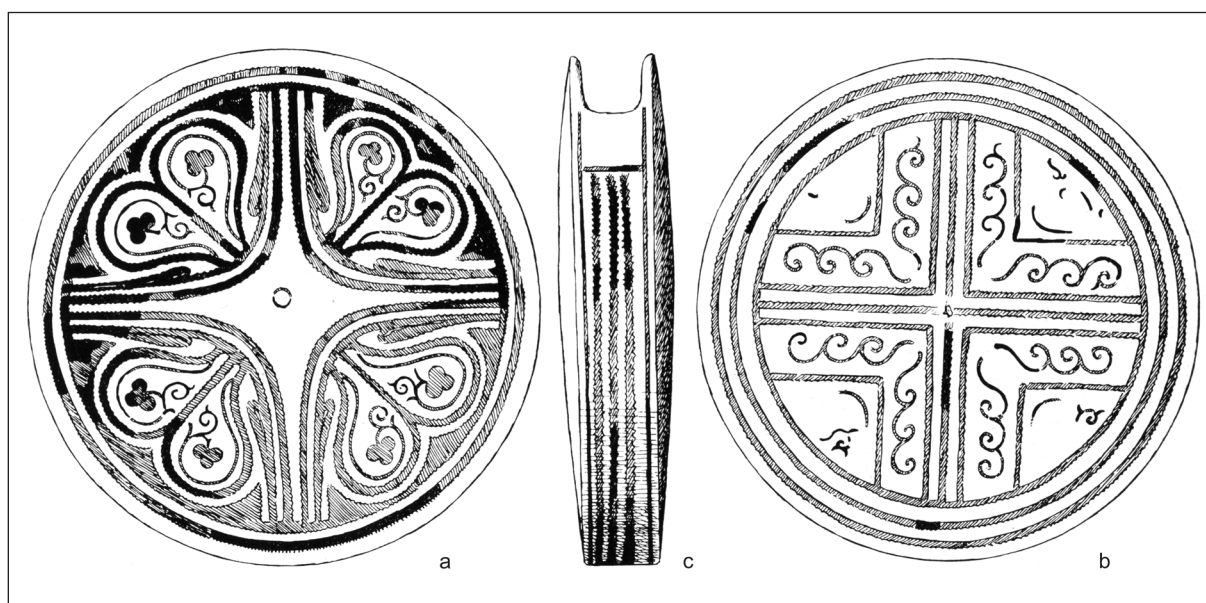

Fig. 7: Drawing of the chape from Zugmantel with reconstructed decoration. Iron, brass. Scale = 1:1 (adapted from Hundt 1953).  
Sl. 7: Risba z rekonstruiranim okrasom zaključka nožnice meča iz Zugmantla. Železo, medenina. M. = 1:1 (po Hundtu 1953).

but there the tendrils are represented in greater detail, more ramified. Furthermore, the intersecting stripes with the motif of continuous spirals on the front side of the chape from Vodice have the only parallel in the decoration on the other side of the same chape from Zugmantel (Fig. 7: b). The decorative fields are not equal, as the stripes with the motif of continuous spirals on the chape from Zugmantel border the central motif of the intersecting lines.<sup>26</sup> The lens-shaped decorative fields bearing a tendril-motif, situated on the edge of the round planes, such as those on the back side of the chape from Vodice, are frequent on the chapes of the first group, but the more ramified tendril-motif is usually complemented by heterogeneous leaves. The central motif of a rosette, but a somewhat smaller one, is represented on the chape from Niederbieber.<sup>27</sup> A superficial comparison of the decoration style, made on the basis of the published drawings, has shown a simplified representation of the motifs on the chape from Vodice in comparison to the other chapes of the first group, known from publications.<sup>28</sup>

The formal and stylistic classification of the chape from Vodice, as well as of the sword, does not make it possible to date the find of the sword with the scabbard slide and the chape more precisely than to the 3rd century. Only the chape which is

most similar to the chape from Vodice regarding the decoration, found at the fort of Zugmantel, abandoned in the year 260 AD at the fall of the *limes*, could indicate a dating to the first half or the middle of the 3rd century.

#### Spearheads

The spearhead (Fig. 8: 4) has no analogies among Roman objects. Its singularity is a short wide socket, a shaft, reaching far into the blade, a thick barbed tip, rhombic in the cross-section and shaped only in relief on the blade, as well as the form of the blade with slightly concave edges, reaching the widest point by the shaft. An identical spearhead was placed by Viktor Hoffiller on his figure representing Roman spearheads from Sisak (*Siscia*) and other sites in Croatia and Slavonija, but without any data whatever on it; hence dating to the Roman period cannot be without doubt.<sup>29</sup>

Because of its shape and the thick tip, rhombic in the cross-section, resembling cross-sections of some younger missiles, the spearhead does not seem to be Roman, but younger, i. e., belonging to the Middle Ages.

Spearheads, resembling in form the spearhead from Vodice (Fig. 8: 5), come from different sites and are dated to various centuries.<sup>30</sup> The authors

<sup>26</sup> *Ib.*, 66, Abb. 1: 2b.

<sup>27</sup> *Ib.*, 66, Abb. 6: 2a.

<sup>28</sup> Martin-Kilcher 1985, Abb. 8; 9; 27: 5; 28: 1; Oldenstein 1976, Taf. 22: 138,140; 23; 24: 146.

<sup>29</sup> Hoffiller 1912, sl. 34 on pg. 96: the second spearhead from the left in the bottom row.

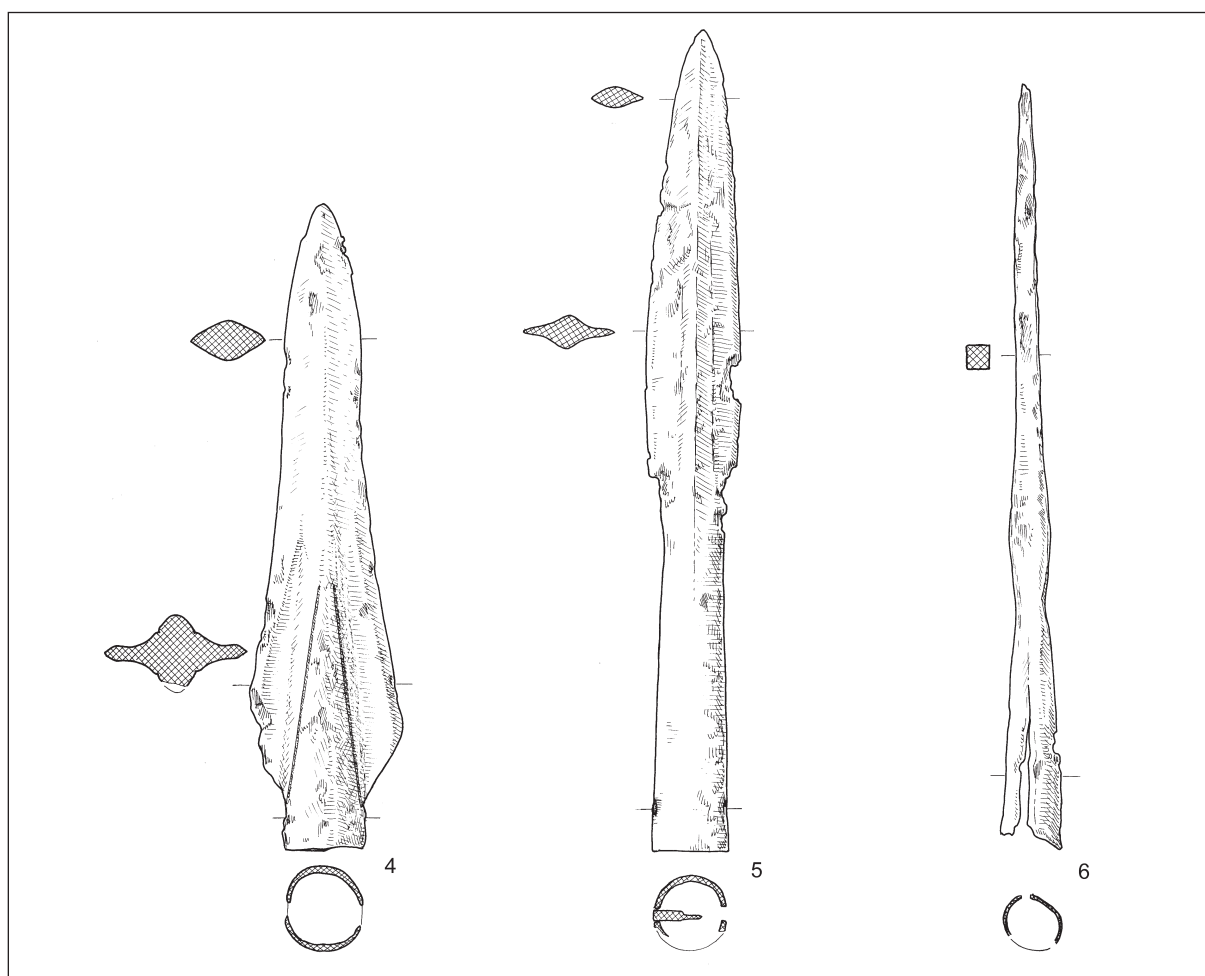

Fig. 8: The two spearheads (4, 5) and the point (6) from Vodice. Iron. Scale = 1:2.  
 Sl. 8: Sulični osti (4, 5) in ost (6) z Vodice. Železo. M. = 1:2.

who have dealt with Roman spearheads stress the difficulty, unsuccessfulness and probably senselessness of attempts at typological classification of spearheads, as due to an assumed occasional manufacture no two spearheads are completely identical. For that reason, spearheads cannot be dated simply on the basis of their shape (some forms remained unchanged for the whole Roman Imperial period), the dating is made possible only by the stratigraphic data of adequately excavated sites.<sup>30</sup> A systematic discussion of spearheads from the Danish bog site Illerup Ådal could be of some

help, as the site has been adequately excavated and documented and the different deposits of objects are precisely dated.<sup>32</sup> J. Ilkjær considered the shape of the blade in the cross-section, measurements and proportions as well as the outline of the blade as the main criteria for formal classification of spearheads. The spearhead from Vodice has exact analogies in some spearheads of type 3 from the Danish site; characteristic of type 3 are a blade rhombic in the cross-section and a shaft continuing into the blade and thus forming a rib.<sup>33</sup> The deposit place B, where spearheads of type 3 have been found, has been dated to the first quarter of the 3rd century (the late period C1b). Equal spearheads from younger bog sites in Denmark (Nydam, Ejsbøl) indicate, in J. Ilkjær's opinion, the possibility that spearheads of type 3 with a

<sup>30</sup> For instance Manning 1985, 166-167, Pl. 79: V 106 (site Hod Hill, middle of the 1st century AD); Hübener 1973, 28, Taf. 18: 1-5 (site Augsburg-Oberhausen, not dated); Bishop, Coulston 1993, Fig. 35: 14 (site Hod Hill, middle of the 1st century AD), Fig. 84: 2 (site Caerleon, 3rd century); Marchant 1990, Pl. 1: 6 (site Housesteads, Hadrianic period or later).

<sup>31</sup> Marchant 1990; Bishop, Coulston 1993, 69, 123, 126, 162; Feugère 1993, 169-171, 247.

<sup>32</sup> Ilkjær 1990.

<sup>33</sup> *Ib.*, 43-44, Taf. 7: BQI, BRU; 8: VHR.

shaft prolonged into the blade belong to the late Imperial period.<sup>34</sup>

The iron point (*Fig. 8: 6*) is composed of a long narrow point, square in the cross-section, and an open socket. Almost completely identical points were found in the nearby fort on Martinj Hrib<sup>35</sup> that had, according to the coin finds, most likely existed only for a short time in the second half of the 4th century (approximately from the sixth decade to the year 388).<sup>36</sup>

Comparable to the point from Vodice are also two *plumbatae* from the late Roman fortress on Hrušica (*Ad Pirum*) with a tapering point, square in the cross-section.<sup>37</sup> Their points are short, but they are equally shaped as the angular part of the point from Vodice. The fortress on Hrušica, according to the coin finds, had been abandoned in the first years of the 5th century,<sup>38</sup> *plumbatae* are, as a type of weapon, otherwise dated to the 4th and 5th centuries.

### Two *plumbatae*

The two *plumbatae* from Vodice (*Fig. 9: 7,8*) can be added to the existing list of a special type of late Roman weapon, its characteristics being an iron head with a leaden weight on the socket and a short, not preserved wooden shaft.<sup>39</sup> The weapon attracted the attention of authors already in antiquity;<sup>40</sup> frequent are also discussions of its archaeological finds.<sup>41</sup> The two finds from Vodice

<sup>34</sup> *Ib.*, 44, 325.

<sup>35</sup> Leben, Šubic 1990, 327, 318 Nos. 24,25, t. 2: 20,21.

<sup>36</sup> Kos 1986, 203-204.

<sup>37</sup> Giesler 1981, 173, Katalog I/L. 9: 180, Taf. 22: 180; Ciglencečki 1994a, Taf. 1: 20.

<sup>38</sup> Kos 1986, 198-199, 201-207.

<sup>39</sup> They were described by an anonymous writer of the essay *De Rebus Bellicis* (written in the years 368/9); in four medieval transcripts of his text they are also depicted, but the depictions do not correspond with his description; Anon. *de rebus bell.* X, XI (Ireland 1979, 10, 30-31, 104, Pl. IX). Besides, descriptions by the anonymous writer do not correspond fully with the archaeological finds. On the form of *plumbatae* also Höck 2003, 70, 72, with bibliography.

<sup>40</sup> Anon. *de rebus bell.* X, XI (Ireland 1979, 10, 30-31, 104); Vegetius, *Epitoma Rei Militaris* I 17, II 15, German translation of the sections in Degen 1992, 140; on arming and fighting with *plumbatae*, as described by Vegetius, reports Koliás 1988, 173-174; Bennett 1991, 59.

<sup>41</sup> First list and typological classification was made by Völling 1991, 288-289, 296-298; an overview, a supplemented list and a map of sites in Degen 1992; Buora 1997; Höck 2003, 69-73, 161, Fundliste 5; on individual finds Barker 1979; Marchant 1990, 2; Bennett 1991; Volpert 1997, 266 No. 49, Abb. 11: 10; Radman-Livaja 2004, 31-32, 127 Nos. 31-35, t. 8: 31,32; 9: 33-35; on manufacture Sherlock 1979; on tests on their use Eagle 1989.

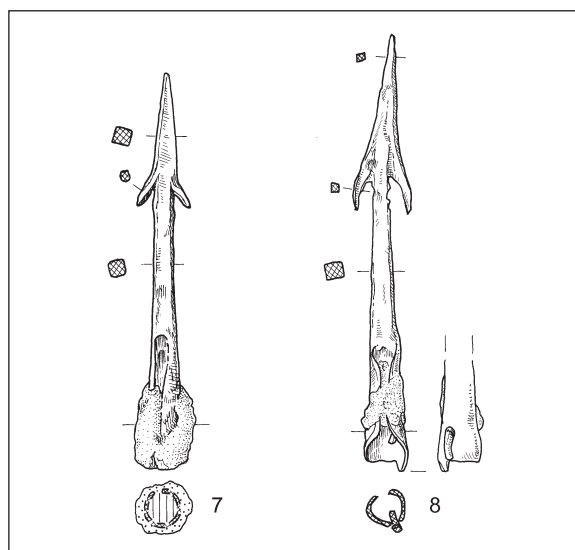

*Fig. 9: The two plumbatae (7, 8) from Vodice. Iron, lead. Scale = 1:2.*

*Sl. 9: Plumbati (7, 8) z Vodice. Železo, svinec. M. = 1:2.*

belong to the most frequent variant of *plumbatae*, having a barbed tip. Rarer are the variants with a tip, square in the cross-section, with a lenticular tip and with a trilobate or three-edged tip.<sup>42</sup>

The finds of *plumbatae* (approximately 70 pieces from 40 sites were published) are limited above all to the region of north-eastern Italy and western Slovenia as well as Great Britain, they appear rarely or singly also along the Rhine and Danube *limes* and in their hinterland in Germany, Switzerland, Austria, Italy, France, the Netherlands, Croatia and Hungary. Isolated finds come from the Lower Danube, Peloponnesos and the eastern Black Sea coast.<sup>43</sup> Anton Höck explains the distribution as a result of the state of research and expects new finds of *plumbatae* also in the interior of the Roman Empire, for instance in Spain and Portugal, as well as across North Africa and Palestine up to the region of Asia Minor.<sup>44</sup>

According to Vegetius, *plumbatae*, also referred to as *mattiobarbuli*, were a special weapon of two Illyrican legions (*legio I Iovia*, *legio I Herculia*) that were employed as elite units in numerous

<sup>42</sup> Höck 2003, 70, Abb. 49.

<sup>43</sup> The last one to supplement the lists of *plumbatae* and the map of sites was Höck 2003, 69 note 458, 71, Tab. 8, 72-73, Abb. 50, 161, Fundliste 5. Previously Völling 1991, 296-298; Degen 1992, Abb. 6; Buora 1997. A new find (*Vindonissa*) was published by Huber 2003, 397 and Hagendorn 2003, 668 No. Me898, Taf. 72: Me898; Kasprzyk 2004, 243, fig. 3: 4 (Escolives-Sainte-Camille); finds from Serbia Christodoulou 2001-2002, 29-31, note 19, fig. 8; 9: B-D.

<sup>44</sup> Höck 2003, 72.

places up to the demise of the (Western) Roman Empire.<sup>45</sup> It remains unclear whether only the two elite legions or also other contemporary units were armed with *plumbatae*.<sup>46</sup>

*Plumbatae* are a late Roman innovation, but they are seldom found in contexts that would allow a more precise dating. The finds that make the dating possible point to the 4th and 5th centuries, perhaps only to the beginning of the 5th century, and even to the end of the 3rd century.<sup>47</sup> Slightly larger darts, similar to *plumbatae*, were known also in the Byzantine weaponry.<sup>48</sup>

Including the two *plumbatae* from Vodice, 11 *plumbatae* from the following sites in Slovenia are known:<sup>49</sup> Ajdna above Potoki (Ajdna nad Potoki) (1),<sup>50</sup> Hrušica (3),<sup>51</sup> Ljubljana (1),<sup>52</sup> Predjama (1),<sup>53</sup> Podutik (1),<sup>54</sup> Velike Malence (1),<sup>55</sup> Vodice (2), Vrhnika (1).<sup>56</sup> They are individual finds or finds from old, methodically inadequate excavations, therefore the contexts of finds that would enable a more precise dating are not known. Only the *plumbata* from Velike Malence has been

found recently, while excavating a *villa rustica* by the church of Saint Martin near Velike Malence. The *plumbata* was found next to an excavated building on a kind of a paved courtyard area that contained coins from between the last third of the 3rd century and the last third of the 4th century. The Roman building complex was destroyed in a fire around the year 378 AD; there are no traces of later activities and no later finds.<sup>57</sup>

## Tools or kitchen implements

### Knives

The study of knives of the Roman period and their classifying into formal groups is made difficult not only by the variety of their forms but also by their bad state of preservation and strong rustiness; for that reason, the shape of the knife is different from the original form. Besides, only rare finds of knives have been more precisely dated within the Roman period.<sup>58</sup> The use of singular forms of knives, except for rare examples, is not precisely known - assumingly they were primarily kitchen implements that could also have been used otherwise in housekeeping, in handicraft or in agriculture. There is no proof, apart from rare exceptions, of a direct connection between the form and the mode of use of a knife.<sup>59</sup>

No analogy, matching in all details, has been found for the well preserved knife from Vodice (*Fig. 10: 9*). Similar in shape, but of a different size, is an individual find of a knife from the site Runder Berg. That knife has a groove on its tapering blade.<sup>60</sup> It is a typical form of knife of the late Imperial period that frequently appears in Germanic graves of the 4th century and in other late Roman contexts. Arm-guards are frequent among knives of this type.<sup>61</sup> A long tang is, according to the statements by Ursula Koch, typical of the knives of the late Imperial period.<sup>62</sup>

Due to the lack of suitable analogies, the knife from Vodice cannot be classified and dated more precisely.

<sup>45</sup> On description by Vegetius Koliás 1988, 173-174; Bennett 1991, 59; Degen 1992, 140.

<sup>46</sup> Degen 1992, 144, 146; Höck 2003, 72; Christodoulou 2001-2002, 31; Buora 1997.

<sup>47</sup> Barker 1979, 97; Degen 1992, 144; Buora 1997, 240-242. Marchant (1990, 2) allows for finds from three British sites dating to the 3rd century or later. Völling (1991, 291) bases the dating to the Late Roman period also on the fact that *plumbatae* are not known from *Dacia* and *limes* in Upper *Germania* and *Raetia* which were abandoned in the seventies of the 3rd century.

<sup>48</sup> On mentioning in written sources Koliás 1988, 175-177; on a find of a Byzantine variant Völling 1991, 287-288, 294-296, Abb. 1.

<sup>49</sup> On some lists of *plumbatae* a find from Martinj Hrib is mentioned as well (Leben, Šubic 1990, 318, t. 2: 18), but the conservational treatment of the object revealed that it is an ordinary spearhead with a barbed tip.

<sup>50</sup> Valič 1985, 267, sl. 95; Valič 1997, 268, sl. 8.

<sup>51</sup> Giesler 1981, 76, 173, Katalog I/L. 9: 180, Taf. 22: 180, 76, 173, Katalog I/L. 9: 179, Taf. 22: 179 (only a leaden weight is preserved); Ciglencečki 1994a, Taf. 1: 20.

<sup>52</sup> Petru 1976, unnumbered pg. 36: the left one in the upper row; Pflaum 2001b, 24.

<sup>53</sup> Korošec 1982, 93, t. 8: 5.

<sup>54</sup> Müllner 1900, Taf. 56: 17; Guštin 1979, 80, t. 80: 3 (it is published under a wrong site, Šmihel; equally Guštin 1973, 486, sl. 3: 23 and Slapšak 1996, 220, the lower figure: 2); Degen 1992, Abb. 4: 9; Pflaum 2001. In publications, most frequently the name Utik is mentioned as the name of the site; it is an old name for the village Podutik near Ljubljana. The *plumbata* was found between the village Podutik and the near hill Toško celo - cf. Šašel 1975. I would like to thank Dr. Dragan Božič for drawing my attention to the wrong naming of the site.

<sup>55</sup> Bavec 2001, 169, sl. 51: 8.

<sup>56</sup> Müllner 1900, Taf. 54: 16; Guštin 1979, 80, t. 80: 4 (it is published under a wrong site, Šmihel); Horvat 1990, 306, sl. 36; Pflaum 2001a.

<sup>57</sup> Bavec 2001, 166-170.

<sup>58</sup> On problems concerning the study of knives Manning 1985, 108.

<sup>59</sup> Schaltenbrand Obrecht 1996, 167; Manning 1985, 108.

<sup>60</sup> Koch 1984, 213, Taf. 22: 1.

<sup>61</sup> *Ib.*, 118, 199. The knife was put into a group of knives with a wide spear-shaped blade.

<sup>62</sup> *Ib.*, 119.

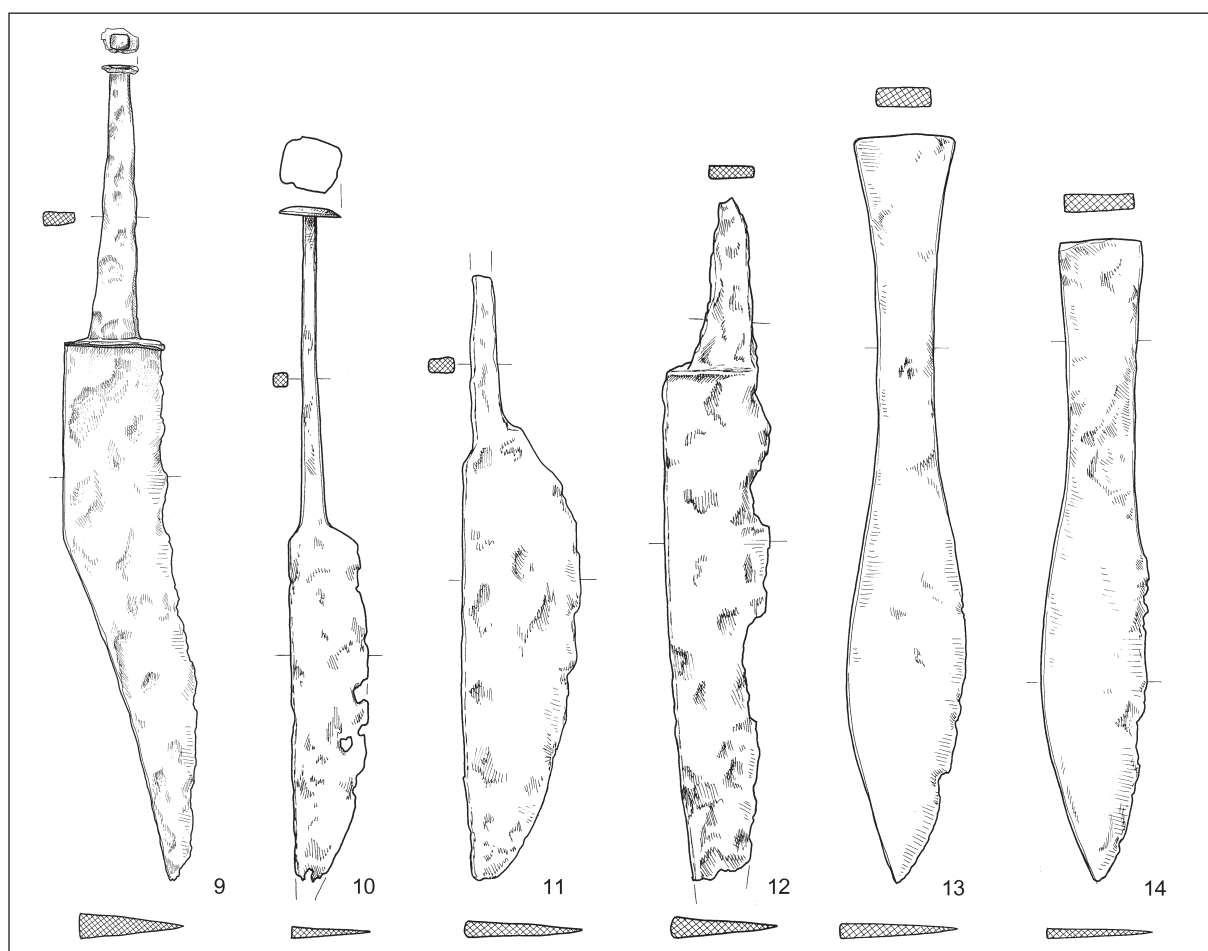

Fig. 10: The knives (9-14) from Vodice. 9 iron, copper?, 10-14 iron. Scale 9 = 1:3; others = 1:2.  
 Sl. 10: Noži (9-14) z Vodice. 9 železo, baker?, 10-14 železo. M. 9 = 1:3; drugo = 1:2.

The knife from Vodice (Fig. 10: 10) resembles, concerning the length and form of the tang and the shoulder, a knife with a badly preserved blade from the site Oberwinterthur (*Vitudurum*) in Switzerland.<sup>63</sup> According to the relative chronology of the site, the knife has been placed into the period II, dated between the years 45/55 and 70/80 AD.<sup>64</sup> Also similar, but longer, is a knife from the site Augsburg-Oberhausen that has not been precisely dated.<sup>65</sup> The long tang, supposedly typical of the knives of the late Imperial period,<sup>66</sup> is also not enough for classifying and dating the knife from Vodice.

The knife from Vodice (Fig. 10: 11) represents the most frequent form of knives of the Roman period,

<sup>63</sup> Schaltenbrand Obrecht 1996, 166-167, 326 No. E 253, Taf. 50: 253.

<sup>64</sup> *Ib.*, 142.

<sup>65</sup> Hübener 1973, 52, Taf. 20: 22.

<sup>66</sup> Koch 1984, 119.

that is with an equally curved cutting edge of the blade, with a straight back edge and a tang set lower than the back edge of the blade. Similar knives were found, for instance, on the sites *Carnuntum*,<sup>67</sup> *Walthamstow*<sup>68</sup> and *Oberwinterthur (Vitudurum)*.<sup>69</sup> Only the knife from the last mentioned site has been dated, it has namely been placed into the periods I/early and II according to the relative chronology of the site. The periods are dated between 7 and around 35 AD and between 45/55 and 70/80 AD.<sup>70</sup> The knife from Vodice can therefore not be more precisely dated within the Roman period.

<sup>67</sup> The knife is of a very similar shape, but shorter (Stiglitz 1986, 210, Taf. 10: 3 on pg. 220).

<sup>68</sup> Manning 1985, 115, Pl. 55: Q49. It is defined as type 15 (*ib.*, 115, Fig. 28: 15 on pg. 109).

<sup>69</sup> Schaltenbrand Obrecht 1996, 326 No. E 250, Taf. 50: 250. It is ranged into the subgroup 1 of group 1, its characteristics being in the first place a tang and in the second place a flat back edge of the blade with a straight transition to the tang (*ib.*, 167, Tab. 72).

<sup>70</sup> *Ib.*, 142, 167, Tab. 72.

The knife from Vodice (*Fig. 10: 12*) is very badly preserved, and that is why classifying on the basis of formal comparisons cannot be successful. Nevertheless, it seems to be almost identical to a shorter knife from *Carnuntum*, found on a causeway and not dated.<sup>71</sup> The analogy thus offers no further help in determining the knife from Vodice.

The knives from Vodice (*Fig. 10: 13,14*) of an almost identical, leaf-shaped form, have practically no analogies amongst numerous and diverse forms of Roman knives. A similar knife, but having rivets on the handle, had been found in the fort in Zugmantel and defined as a rare, unusual form of knife for cutting leather.<sup>72</sup> The knife has not been dated, the fort in Zugmantel, however, was built at the end of the 1st century AD and abandoned at the fall of *limes* in the year 260 AD.<sup>73</sup> In Slovenia, an identical knife was found during the excavations of a late Roman house at Ajdovščina above Rodik (Ajdovščina nad Rodikom),<sup>74</sup> therefore the two knives from Vodice can possibly also be dated into the same period.

### Measuring instrument

#### *Steelyard*

Discussions on ancient steelyards focus on metrological analyses (on essays to decipher and reconstruct the scales, on essays to calculate the span of load capacity of a steelyard and on the ratios between lengths of the two arms with regard to the different centres of motion)<sup>75</sup> or on typological classifications.<sup>76</sup> The bronze steelyard from Vodice (*Pl. 1: 15; Fig. 11*) is almost entirely preserved, including the weight, only one hook for suspending the object to be weighed is missing. Three hooks for the suspension of the steelyard at three different positions made it possible to weigh loads of different weight. Three scales corresponding to the three centres of motion are preserved to a different extent. The first scale is clearly visible: it is divided into 12 units, from 1 to 12 pounds (*librae*). The

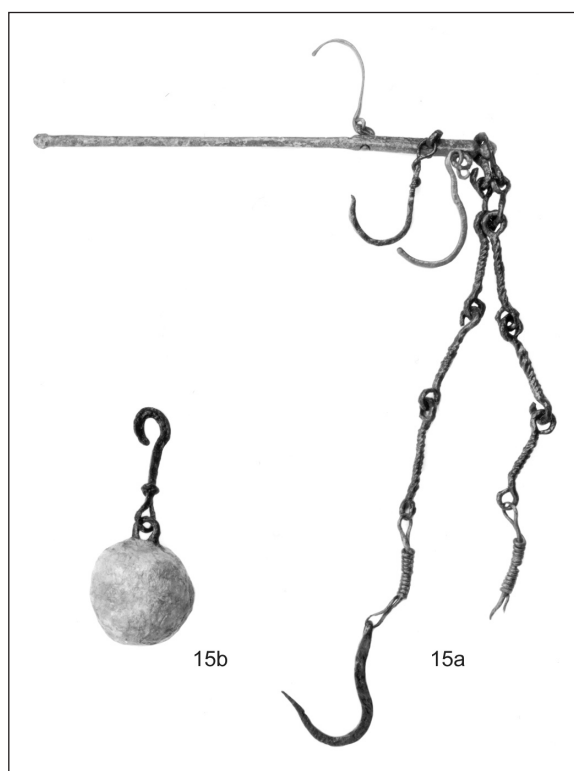

*Fig. 11: The steelyard (15a) and its weight (15b) (Pl. 1) from the hoard from Vodice. Not in scale (photo T. Lauko, NMS).*

*Sl. 11: Tehtnica (15a) z utežjo (15b) (t. 1) iz zakladne najdbe z Vodice. Brez merila (foto: T. Lauko, NMS).*

interspaces between two successive marks are 1.4 to 1.6 cm long, the average unit-length is 1.51 cm. The poorly visible marks of the second scale reveal that the units of the second scale were slightly more than half as long as the units of the first scale, the average unit-length is 0.65 cm. If we extrapolate the distance between the better visible marks X and V to the remainder of the scale-arm, we can ascertain that the second scale was used to weigh loads from 10 to 37 pounds (*librae*). We get the same span of load capacity by means of a calculation, using the formula  $Ww \times Lsa = Lao \times (Ws + Wl)$  (where  $Ww$  = weight of the leaden weight [in our case 1486 g or 4.5 *librae*];  $Lsa$  = length of the scale-arm or, more precisely, the distance between the chosen mark on the chosen scale and the corresponding loop for suspending the steelyard [the centre of motion];  $Lao$  = length of the arm for suspending the object to be weighed or, more precisely, the distance between the centre of motion and the point [the groove] where the load is suspended;  $Ws$  = weight of the chain-suspension [in our case it has been ignored, because the suspension is not entirely preserved and because it could not be weighed];  $Wl$  = weight of the load [the unknown]; 1 *libra* = 327.45 g). On the third scale, the initial XXX mark

<sup>71</sup> Stiglitz 1986, 210, Taf. 10: 2 on pg. 220.

<sup>72</sup> Pietsch 1983, 78, 121 No. 597, Taf. 27: 597. On similar knives for leather also Gaitzsch 1980, 122, 126, Abb. 13 on pg. 123.

<sup>73</sup> Pietsch 1983, 6-7.

<sup>74</sup> Slapšak 1999, 162, the left bottom figure: the knife above the bells.

<sup>75</sup> For example Mutz 1983; Mutz 1988; Garbsch 1988, 202-209; a list of discussions on metrological questions concerning ancient steelyards has been made by Franken 1993, note 5.

<sup>76</sup> Franken 1993.

is poorly visible, with more or less visible V and X marks alternating thereafter. Using the presented formula, we can calculate that the load capacity of the third scale spanned the range between 30 and 100 pounds (*librae*). The units of the third scale were more than half shorter than the units of the second scale; the average unit-length is 0.27 cm, the interspaces between two successive marks for sections of five units are 1.2 to 1.4 cm long. To summarize, the steelyard from Vodice was used to weigh loads from 1 to 100 pounds (*librae*) or approximately from 1/3 to 32.7 kg.

The steelyard from Vodice is most evidently not preserved in its original form: the middle loop, the middle and the right-hand suspension-hooks and the iron parts of the chain-suspension are later substitutions. The preserved parts of the original steelyard correspond, as to their form, to the early group of the Osterburken type as defined by Norbert Franken.<sup>77</sup> On the steelyard from Vodice, two out of three formal details, used by N. Franken as the main criteria for defining the early group, are present: the two bronze chain-links are made out of long pieces of wire in such a way that the bent end of the wire is spirally wound round the middle of the link; the left-hand suspension-hook is shaped like a question mark - a straight part is followed by a curve. The omega-shaped chain-link is not made out of a bent wire, as characteristic of the steelyards of the early group of the Osterburken type, but is iron and laterally flattened. Such bronze flat links are characteristic for the steelyards of the late group of the Osterburken type as well as for the steelyards of the Konstantinopel (Constantinople) type: according to N. Franken,<sup>78</sup> a similar iron link is part of the steelyard from Ljubična above Zbelovska Gora (Ljubična nad Zbelovsko Goro)<sup>79</sup> of the Gora type as defined by Dragan Božič.<sup>80</sup> Comparable to the two steelyards of the Gora type are also the spirally twisted iron chain-suspension links of the steelyard from Vodice. The third (the right-hand) suspension-hook of the steelyard from Vodice, with its bottom end bent backwards in form of an *s*, resembles hooks of the steelyards of the Konstantinopel type.<sup>81</sup>

N. Franken assumes on the basis of hypotheses on the history of development of steelyards that steelyards of the early group of the Osterburken type belong to the second half of the 2nd century

and to the first half of the 3rd century; whereas the steelyards of the late group belong to the later 3rd century.<sup>82</sup> D. Božič established a later dating of the late group, putting it mainly into the 4th century.<sup>83</sup> Consequently, we could probably also prolong or shift the dating of the early group to a later time, possibly to the whole 3rd century. The Gora type is hypothetically dated to the 4th century,<sup>84</sup> the Konstantinopel type is dated mainly to the 5th and 6th centuries.<sup>85</sup> Because of the later substitutions (mendings) on the steelyard from Vodice which correspond to the younger types of steelyards, we can conclude that the steelyard was in use over a long period of time, probably still during the entire 4th century.

Iron or bronze steelyards are also included in some other hoards from the territory of Slovenia, but they belong to other, younger types. Two iron steelyards of the newly determined Gora type were found as part of the third hoard from Gora above Polhov Gradec (Gora nad Polhovim Gradcem), dated to the second half of the 4th century and the beginning of the 5th century,<sup>86</sup> and as part of hoard I from Ljubična above Zbelovska gora, dated to the 6th and 7th century;<sup>87</sup> this dating has been refuted by D. Božič on the bases of analogies from late Roman hoards and the hypothetical dating of the steelyard-type to the 4th century.<sup>88</sup> Two iron steelyards and a bronze one are included in the long-known supposed hoard from Ajdovski gradec above Vranje (Ajdovski gradec nad Vranjem), dated to the later period of the settlement (after the 4th century);<sup>89</sup> some other finds would point against such late dating, for example a fibula with onion-shaped knobs<sup>90</sup> of type 3/4 B according to Philipp M. Pröttel's typology, dated between approximately the year 330 and the year 400 AD, or most likely, to the later part of this period.<sup>91</sup> The bronze steelyard from Ajdovski gradec belongs to the Konstantinopel type, while the longer iron steelyard is, as seen on the photograph,<sup>92</sup> quite similar to the bronze one; the shorter iron steelyard is more poorly preserved and details are not discernible on the photograph.<sup>93</sup>

<sup>82</sup> Franken 1993, 89.

<sup>83</sup> Božič 2005, 353, 367.

<sup>84</sup> *Ib.*, 353.

<sup>85</sup> Franken 1993, 93.

<sup>86</sup> Božič 2005, 351, 353, 356, 361, Abb. 20.

<sup>87</sup> Gaspari et al. 2000, 192, 200, Nos. 15, 16, Fig. 8: 15,16; Gaspari 2001, 58.

<sup>88</sup> Božič 2005, 356.

<sup>89</sup> Riedl, Cuntz 1909, 3-5, 34, Fig. 5: a-d, Fig. 6, 7.

<sup>90</sup> *Ib.*, Fig. 5: k; Knific 1979, 748, sl. D.

<sup>91</sup> Pröttel 1988, 359, 361-364.

<sup>92</sup> Riedl, Cuntz 1909, Fig. 5: b.

<sup>93</sup> *Ib.*, Fig. 5: c.

<sup>77</sup> *Ib.*, 85-89, Abb. 8, 10.

<sup>78</sup> *Ib.*, 87, 89-94, Abb. 11, 12: F; Garbsch 1988, 209.

<sup>79</sup> Gaspari et al. 2000, 195, Fig. 8: 15.

<sup>80</sup> Božič 2005, 353.

<sup>81</sup> Garbsch 1988, Abb. 3, Taf. 28; Mutz 1988, Taf. 33; Franken 1993, Abb. 11.



## Tools

### Axes

The wide axes from Vodice (*Pl. 2: 16-18*) differ one from another only in size and formal details (the shape of the cutting edge, of the back edge of the blade and the head). All three have a blade that is prolonged backwards, with a straight-cut edge. Such and similar wide axes appear mainly in the Late Roman period, some pieces already in the Middle Roman Imperial period.<sup>94</sup>

Similar, well-dated wide axes with low rectangular side pieces were found; for example, three pieces in the large hoard from Weißenburg, buried probably in the second half of the 3rd century,<sup>95</sup> one axe in a hoard from the well 7 of the *vicus* Rainau-Buch, buried at the same time,<sup>96</sup> and one axe at Moosberg, where the first stage of the building up of the settlement is dated to the second half of the 3rd century, whereas the second stage is dated to the second half of the 4th century.<sup>97</sup>

The two axes from Vodice (*Pl. 2: 19, 20*) differ one from another in size and details, but they both belong to a strictly limited group of axes of the Roman period. These axes differ from others in the typical form of the back of the head, elongated forwards and backwards, usually with small tines in the corners. Finds of such axes are limited to the region of *Pannonia*, *Noricum* and northern *Illyricum* (including the north-eastern edge of *Italia*); they almost never appear elsewhere. According to the contexts of finds it seems that they belong above all to the 3rd century and to the Late Roman period.<sup>98</sup> The two axes from Vodice resemble, for instance, the two axes from *Lauriacum*. The first of the latter two, similar to the axe (*Pl. 2: 20*) from Vodice, was found in the bath to the west of the civilian town that was probably in use at the end of the 2nd and in the first half of the 3rd century.<sup>99</sup> The second one, similar to the axe (*Pl. 2: 19*) from Vodice, comes from the area of a legionary camp and probably belongs to the 3rd and 4th centuries.<sup>100</sup>

Compared to other areas, finds of such axes are extraordinarily numerous on the territory of Slovenia, which can be said to be situated in the centre of distribution of axes with an elongated back of the head. As to the form, they are for the most part similar to the second axe from Vodice (*Pl. 2: 20*), having a narrow blade, asymmetrically widening downwards, but also having the small tines on the back of the head. A list of sites of eleven published finds, known at the time, and four unpublished finds has been presented by Polona Bitenc.<sup>101</sup> Furthermore Reinhard Pohanka mentions an axe from Ljubljana (*Emona*)<sup>102</sup> and another one from Gornji Zemon,<sup>103</sup> and Joachim Henning mentions an axe from Orešje in the Bizeljsko region.<sup>104</sup> Some recently published axes with an elongated back of the head, contained in hoards of iron tools from the following sites, can be added to the list: Sv. Pavel above Vrtovin (Sv. Pavel nad Vrtovinom; the context in which the hoard was found is not known and the hoard has not been dated; the settlement on Sv. Pavel, however, existed from the 4th to the 6th century),<sup>105</sup> Ljubična above Zbelovska Gora (two axes; the hoard II has been dated to the 3rd and 4th centuries),<sup>106</sup> Limberk above Velika Račna (the hoard has been dated into the years around 400 AD).<sup>107</sup>

An elongated back of the head as a formal particularity appears also on other contemporary tools of a similar form - for instance on wide axes and carpenter's axes. Such wide axes were found in some late Roman hoards of tools<sup>108</sup> and as individual finds in the river Ljubljanica and on Nanos,<sup>109</sup> on a Roman hill-top post of the second half of the 3rd century on Veliki vrh above Osredek near Podsreda (Veliki vrh nad Osredkom pri Podsredi)<sup>110</sup> as well as on a Late Antiquity hill-top

<sup>101</sup> Bitenc 1997, 12, with bibliography.

<sup>102</sup> Pohanka 1986, 241 note 2. It is kept in the Kunsthistorisches Museum in Vienna.

<sup>103</sup> *Ib.*, 241 note 3; Božič, Ciglencečki 1995, 258 note 94 (older bibliography on the find).

<sup>104</sup> Henning 1987, Abb. 1: 90 on pg. 61, 72 a list; Mlinar 1965, 71, sl. 9.

<sup>105</sup> Gaspari et al. 2000, 192, 194, 196 No. 34, Fig. 11: 34.

<sup>106</sup> Bitenc 2001, 14 Nos. 14: 7,8, sl. 14: the lower two on the left (there is a mistake in numbering on the sketch in comparison with the catalogue descriptions).

<sup>107</sup> Bitenc, Knific 2001a, 32 No. 87: 16. In the same hoard there are also two fragments of an axe-like tool with a preserved elongated back of the head and a part of the head (No. 87: 61,62). It is not possible to deduce what the blades looked like (whether they were axes, wide axes or carpenter's axes).

<sup>108</sup> A list of nine wide axes from five sites in Slovenia in Božič 2005, 313.

<sup>109</sup> Bitenc 2001a, 14 No. 13.

<sup>110</sup> Ciglencečki 1990, 150 No. 25, 165-166, t. 3: 4.

<sup>94</sup> Pietsch 1983, 15, Abb. 5: 2.

<sup>95</sup> Kellner, Zahlhaas 1983, 48, 43 Nos. 99-101, Abb. 32.

<sup>96</sup> Kaufmann-Heinimann 1998, 272 No. GF61, Abb. 234.

<sup>97</sup> Garbsch 1966, 72, 85, Taf. 22. 19; 31: 13.

<sup>98</sup> Pohanka 1986, 229, 239-242, Textabbildung 14: Typ 3; a somewhat incomplete map of sites of such axes and wide axes was published by Henning 1987, 61, 64, Abb. 1 on pg. 61, 72-73 list of sites; Bitenc 1997, 11-12, 28-29, Nos. 33-38, sl. 4 on pg. 12, sl. 33-38.

<sup>99</sup> Pohanka 1986, 240-241, 376 No. 199, Taf. 45: 199.

<sup>100</sup> *Ib.*, 240-241, 376 No. 198, Taf. 45: 198.

settlement Krvavica near Vransko (Krvavica pri Vranskem).<sup>111</sup> A carpenter's axe with an elongated back of the head is, for example, contained in the hoard from Limberk above Velika Račna.<sup>112</sup>

Axes with an elongated back of the head were in use also after the Late Roman period, but it is difficult to distinguish them from the Roman ones.<sup>113</sup>

According to P. Bitenc, a production of the late Roman axes with an elongated back of the head can also be supposed to have taken place somewhere on the territory of Slovenia, considering the high number of such axes from sites in Slovenia (more than 24 axes, 13 wide axes and 1 carpenter's axe are listed, and the list is certainly not complete).<sup>114</sup>

#### *Adzes and hoes*

A typology of Roman adzes has been made by Martin Pietsch. He classifies them into four consecutive types. The two adzes from Vodice (*Pl. 3: 21,22*) both match the late Roman type IV, its characteristics being a blade slightly curving downwards, the sometimes concave edges of the blade, the sometimes almost right angle between the blade and the (non-preserved) helve and a low head with a hafting hole of diverse shapes - round, oval, quadrangular. Adzes of the type IV are dated by M. Pietsch between 260 and around 400 AD.<sup>115</sup>

Adzes of a similar form were found on some other late Roman sites in Slovenia as well - for example in hoards of tools from Grdavov hrib near Radomlje (Grdavov hrib pri Radomljah),<sup>116</sup> Ljubična above Zbelovska Gora II<sup>117</sup> and Sv. Pavel above Vrtovin.<sup>118</sup>

<sup>111</sup> Krempuš 2000, 213 No. 2, Abb. 3: 2 on pg. 216. He dates the wide axe on the basis of analogies to the late 3rd and early 4th centuries. Also Bitenc 2001b.

<sup>112</sup> Bitenc, Knifc 2001a, 32-33 No. 87: 24, sl. 87: 24.

<sup>113</sup> I would like to thank Polona Bitenc (National museum of Slovenia) for presenting to me orally the information on younger axes with an elongated back of the head and on the possibilities of distinguishing them from the Roman ones. On the method of manufacturing the axes Pleiner 1967, 79-83, Abb. 1 on pg. 80; Bitenc 1997, 4-5.

<sup>114</sup> Bitenc 1997, 23.

<sup>115</sup> Pietsch 1983, 27-28, Abb. 11: 2, Abb. 26 on pg. 81.

<sup>116</sup> Sagadin 2000, Pl. 2: 1-3; Sagadin 2001, 15 Nos. 15: 16,19,20, sl. 15: 16,19,20. He dates the hoard only inexactly to the second half of the 3rd century and to the 4th century, Božič (2005, 313) however supposes that the hoard could be dated to the years around 400 AD.

<sup>117</sup> Bitenc 2001, 14 No. 14: 5, sl. 14: middle-on the right side (there is a mistake in the numbering on the sketch in comparison with the catalogue descriptions).

<sup>118</sup> Gaspari et al. 2000, 192, 194-195 Nos. 25, 27, 196 No. 33, Fig. 10: 25,27; 11: 33.

The double-bladed adze from Vodice (*Pl. 3: 23*) has two blades, the first one with a straight cutting edge, the second one with a vaulted cutting edge. Finds of double-bladed adzes are very rare; they only appear on sites in Roman provinces.<sup>119</sup> A very similar double-bladed adze to the one from Vodice was found in Lower Austria in a hoard named Mannersdorf II; the burying of the hoard is dated to the 4th/5th centuries.<sup>120</sup>

Hoes with two prongs and a hoe-shaped blade (*Pl. 3: 24*) are a frequent type of Roman tools, they differ mostly in the shape and curving of the prongs and of the blade, as well as in the shape of the head.<sup>121</sup> Only a few hoes are well dated; they appear on the territory of Roman provinces without interruption from the Early to the Late Roman period.<sup>122</sup> The two most similar hoes to the hoe from Vodice, but with a narrower blade, were found - the first one in a late Roman hoard from Celje<sup>123</sup> and the second in Saalburg.<sup>124</sup>

#### *Other tools*

A hammer from Vodice (*Fig. 12: 25*) is, as a type of tool, similar to a group of scarce supposedly Roman claw hammers with a cleft end of the head, designed for pulling out nails.<sup>125</sup> Claw hammers appear on Roman sites of different centuries, but it is not possible to date them more precisely on the basis of differences in their shape. Some medieval hammers are also similar in form.<sup>126</sup> The hammer from Vodice has no analogy amongst the supposedly Roman hammers of such form that would be a match also in details, not only as a type of tool. Because of the round end of the head and a claw with one triangular tip, appearing on carpenter's hammers still in recent past,<sup>127</sup> the hammer from Vodice most probably belongs to the Middle Ages or to the modern times.

<sup>119</sup> Gaitzsch 1980, 45-46.

<sup>120</sup> Pollak 2006, 25-26, 31, 39, Abb. 35, Taf. 56: 34.

<sup>121</sup> Pietsch 1983, 19-20; White 1967, 66-68 (group 12. (ii) *Ascia/rastrum*), Fig. 43 on pg. 67; Rees 1979, 309-310 (iii. *Ascia-Rastrum*), Fig. 85-87.

<sup>122</sup> Rees 1979, 310.

<sup>123</sup> Gaspari et al. 2000, 190 No. 1, Fig. 6: 1.

<sup>124</sup> Pietsch 1983, 90 No. 68, Taf. 5: 68.

<sup>125</sup> Gaitzsch 1980, 88, 90-91 (listed are some pieces), 350 No. 84 (a hammer from *Pompeii*), Abb. 9 on pg. 81, Taf. 9: 84 and 16: 84 resp.; Pietsch 1983, 24, 91 No. 106, Taf. 7: 106.

<sup>126</sup> For example from the site Runder Berg (Koch 1984, 136, 222, Taf. 35: 1).

<sup>127</sup> For the information on the shape of recent carpenter's hammers I would like to thank Dr. Dragan Božič.

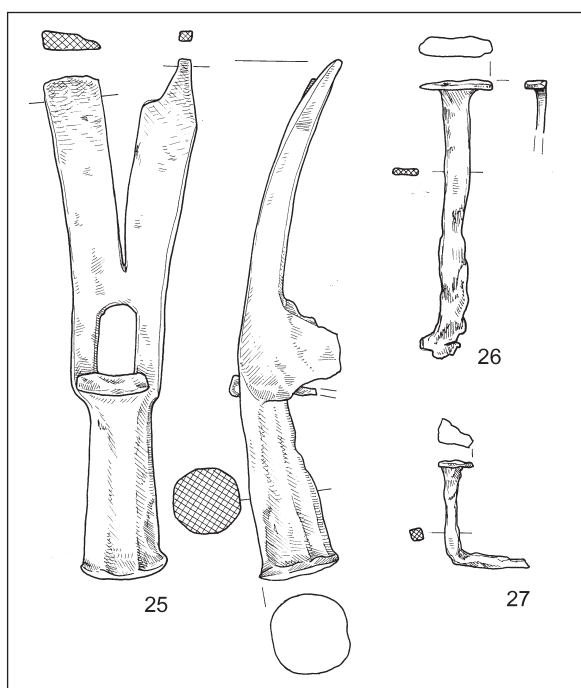

Fig. 12: The claw hammer (25) and two nails (26, 27) from Vodice. Iron. Scale = 1:2.

Sl. 12: Kladio (25) in dva žebnja (26, 27) z Vodice. Železo. M. = 1:2.

The iron *knife* (Pl. 3: 28) is a part of a small group of almost completely identically-shaped curved knives. The use of these knives has for long been unknown, most frequently they were defined as knives for the cutting of forage or the like (Ger. *Futterschneidermesser*),<sup>128</sup> and otherwise ranged into various groups of tools - for example into a group of billhooks or similar knives.<sup>129</sup> Heimo Dolenz<sup>130</sup> and Milan Sagadin<sup>131</sup> have proved, however, the first one on the basis of a depiction of cooper's tools on a sepulchral stele from *Aquileia*, the second one on the basis of ethnological analogies from the Netherlands (knives used in making clogs), that such knives were used to manufacture wooden objects. The knife was fixed to a solid base by the loop<sup>132</sup> and not by the tang,<sup>133</sup> which made it possible to turn the knife in every direction.

The finds of woodworking knives are known above all from the north-eastern provinces of the

Roman Empire and from the northeastern part of *Italia*, that is the eastern Alpine and Pannonian region. Most of them are dated on the basis of contexts to the Late Roman period,<sup>134</sup> and there are no real arguments for later or earlier dating of singular pieces (H. Dolenz mentions two earlier finds from *Virunum* and the already-mentioned depiction on the stele from *Aquileia*, dated to the 2nd century).<sup>135</sup>

From the sites in Slovenia, three finds of woodworking knives have been published. The knife from Ajdovski gradec above Vranje was found in house A with small finds dating between the 3rd/4th century and the 6th century.<sup>136</sup> The knife from Grdavov hrib near Radomlje was contained in a hoard of tools dated to the time from the second half of the 3rd century up to the end of the 4th century<sup>137</sup> or more precisely to the years around 400 AD.<sup>138</sup> The third knife was found on Limberk above Velika Račna as a part of a hoard of iron objects. The hoard has been dated to the years around 400 AD.<sup>139</sup> The fourth knife was found in 2003 on Gradišče near Trnovo in Ilirska Bistrica (Gradišče pri Trnovem v Ilirski Bistrici) as a part of a hoard and has not yet been published.<sup>140</sup>

The *gimlet* from Vodice (Pl. 4: 29) belongs amongst the so called gimlets with a spoon bit, the most frequent form of gimlets of the Roman period. A typological classification of Roman gimlets was made by M. Pietsch on the basis of the shape of their spoon bits and tangs. He found out that spoon bits with the widest point below the middle of their length are more frequent on gimlets of the Early and Middle Roman Imperial period, but they also appear in the Late Antiquity, whereas spoon bits with the widest point above the middle of their length appear almost exclusively on gimlets from complexes, dated to the Late Antiquity, and from non-Roman complexes. As for the tangs, he recognized a development from wide triangular tangs, clearly separated from the shaft, in the Early and Middle Roman Imperial period towards narrow longer tangs, less sharply separated from the shaft, in the Late Roman period.<sup>141</sup> The tang of the gimlet from Vodice matches

<sup>128</sup> For example Pohanka 1986, 265-267, 383 No. 232, Taf. 50: 232, Textabbildung 18/above; Knific 1979, 758-759 (straw cutter).

<sup>129</sup> Popović 1988, 81, t. 13: 5 and 44: 4; Müller 1982, 340 No. 1491, fig. 24: II.2 on pg. 506, 410 No. 1996, 831.

<sup>130</sup> Dolenz 1998, 208.

<sup>131</sup> Sagadin 2000, 205, fig. 1; Sagadin 2000a, 560.

<sup>132</sup> Knific 1979, 758; Sagadin 2000, 205.

<sup>133</sup> For example Pohanka 1986, Textabbildung 18/above.

<sup>134</sup> Pohanka 1986, 265.

<sup>135</sup> Dolenz 1998, 208.

<sup>136</sup> Knific 1979, 733 No. 18, 741-742, 750, sl. 18 on pg. 765; Knific 2001, 52 No. 146.

<sup>137</sup> Sagadin 2000, 205-206, Pl. 2: 6; Sagadin 2001, 14-15 No. 15: 3, sl. 15: 3.

<sup>138</sup> Božič 2005, 313.

<sup>139</sup> Bitenc, Knific 2001a, 32 No. 87: 17.

<sup>140</sup> Božič 2005, 313-314 note 18.

<sup>141</sup> Pietsch 1983, 43-44.

the description of the tangs of gimlets from the Late Roman period, whereas the spoon bit with its widest point below the middle of its length matches the spoon bits that are more usual on gimlets from the Early and Middle Roman Imperial period, but also appear later. The gimlet from Vodice has a shank, round in the cross-section that is rare; shanks, octagonal or square in the cross-section, are more frequent.

In Slovenia, gimlets with a spoon bit regularly appear in the settlements and hoards of the Late Roman period or the Late Antiquity - for example in hoard I from Ljubična above Zbelovska Gora,<sup>142</sup> in the hoard from Celje, found in a large building with a hypocaust from the 4th century,<sup>143</sup> five pieces in the hoard from Grdavov hrib near Radomlje,<sup>144</sup> five pieces in the hoard from Limberk above Velika Račna,<sup>145</sup> on a Late Antiquity hill-top settlement Krvavica near Vransko,<sup>146</sup> on a Late Antiquity hill-top settlement Tonovcov grad near Kobarid (Tonovcov grad pri Kobaridu),<sup>147</sup> two pieces on a Late Antiquity hill-top settlement Ajdovski gradec above Vranje<sup>148</sup> and on a late Roman fortified post Ančnikovo gradišče near Jurišna vas (Ančnikovo gradišče pri Jurišni vasi),<sup>149</sup> two pieces of gimlets, similar to the gimlet from Vodice, have also been excavated in Drnovo near Krško (Drnovo pri Krškem, *Neviodunum*)<sup>150</sup> and on Ajdovščina above Rodik.<sup>151</sup> The tangs of all the listed gimlets correspond to Pietsch's description of the tangs of the Late Roman period. By contrast, most of the spoon bits of the listed gimlets (as far as can be seen from the published drawings and photos) have their widest point below the middle of their length, which is, according to Pietsch, more usual, but not exclusive, on gimlets from the Early and Middle Roman Imperial period. On late Roman gimlets from the sites in Slovenia spoon bits with their widest point below the middle of their

length markedly predominate,<sup>152</sup> therefore it can be concluded that such a form of spoon bits is altogether usual also in the Late Roman period and that the place of the widest point of the spoon bit is not a suitable criterion for the chronological classification of gimlets.

The iron *pair of compasses* from Vodice (*Pl. 4: 30*) belongs, according to its form, to a group of Roman compasses with a short pin, hammered into a low convex head on both sides or flattened on one side and with a convex head on the other. The second group consists of compasses with a smaller, pointed pin stuck into the main pin, prolonged on one side, designed for fixing the legs when used.<sup>153</sup> With its 36.4 cm of length, the pair of compasses from Vodice is quite long. Iron and bronze compasses appear throughout the Roman Imperial period, but their formal spectrum and chronological development have not yet been studied.

In Slovenia, some compasses resembling the pair of compasses from Vodice were found in the late Roman complexes of finds, often in hoards of iron tools.<sup>154</sup> Most of the finds are of similar length (more than 30 cm) to the pair of compasses from Vodice and have equally shaped legs, but they have a pin pierced by a smaller pin on its prolonged side. Such compasses have been found, for example, in the hoard from Grdavov hrib near Radomlje,<sup>155</sup> in the hoard from Limberk above Velika Račna,<sup>156</sup> in the hoard from Merišče near Povir (Merišče pri Povirju), found in a building, dated to the second half of the 4th century,<sup>157</sup> and in hoard I from Ljubična above Zbelovska Gora.<sup>158</sup>

The *anvil* from Vodice (*Pl. 4: 31; Fig. 13*) belongs to the simple so-called block-anvils of the Italic type according to W. H. Manning or of type B according to Wolfgang Gaitzsch (a more detailed typological classification of anvils). They are relatively small self-standing block-shaped or cubiform

<sup>142</sup> Gaspari et al. 2000, 191-192 No. 13, Fig. 7: 13; Gaspari 2001, 58 No. 168; Božič 2005, 356.

<sup>143</sup> Gaspari et al. 2000, 190 No. 10, Fig. 7: 10 on pg. 194.

<sup>144</sup> Sagadin 2000, Pl. 1: 1-5; Sagadin 2001, 15 Nos. 15: 11-15, sl. 15: 11-15; Božič 2005, 313.

<sup>145</sup> Bitenc, Knific 2001a, 32-33 Nos. 87: 31,33,34,49,50, sl. 87: 31,33,34,49,50.

<sup>146</sup> Krempuš 2000, 219 No. 48, Abb. 5: 48 on pg. 222. The gimlet is dated only to the period of existence of the settlement, that is from the middle of the 3rd century to the end of the 6th century. Also Bitenc 2001b.

<sup>147</sup> Ciglencečki 1994, 7, t. 4: 7.

<sup>148</sup> Ciglencečki 1994a, Taf. 8: 11; Knific 2001.

<sup>149</sup> Strmčnik 1997, 281 Nos. 7, 8, t. 6: 7,8.

<sup>150</sup> Petru, Petru 1978, 66, t. 21: 1,14.

<sup>151</sup> Slapšak 1997, 58, sl. 9: the left one in the second row.

<sup>152</sup> Only the gimlets from Limberk above Velika Račna are different; at least some of them have spoon bits with their widest point above the middle of their length.

<sup>153</sup> Manning 1985, 11-12; Pietsch 1983, 61.

<sup>154</sup> A list of compasses from sites in Slovenia in Murgelj 2000, 55-56.

<sup>155</sup> Sagadin 2000, 205, Pl. 1: 9; Sagadin 2001, 15 No. 15: 24, sl. 15: 24; Božič 2005, 313.

<sup>156</sup> Bitenc, Knific 2001a, 32-33 No. 87: 58, sl. 87: 58.

<sup>157</sup> Osmuk 1976, 82, 78 No. 29, t. 4: 7. The pair of compasses is the one most of all resembling the piece from Vodice, having plates of a triangular shape with convex sides. Gaspari et al. 2000, 187 date the hoard to the 4th century.

<sup>158</sup> Gaspari et al. 2000, 191-192 No. 11, 198, Fig. 7: 11; Gaspari 2001, 58 No. 168; Božič 2005, 356.

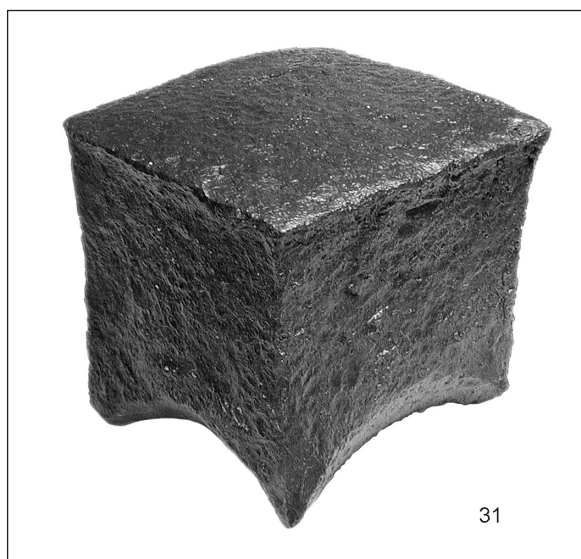

Fig. 13: The anvil (31) (Pl. 4: 31) from the hoard from Vodice. Not in scale (photo NMS).  
Sl. 13: Nakovalo (31) (t. 4: 31) iz zakladne najdbe z Vodice. Brez merila (foto: NMS).

(type B according to W. Gaitzsch) anvils, slightly narrowing towards a vaulted bottom face, thus forming four small legs in the corners.<sup>159</sup> Block-anvils with small legs are known for example from Pompeii, from a sepulchral relief from Aquileia with a scene from a blacksmith's workshop<sup>160</sup> and from Sarmizegetusa Regia in Romania.<sup>161</sup> The type of the anvil was evidently present already in the Early Roman Imperial period, that is in the 1st century, but there are no elements yet for a more precise dating, especially in later centuries.

## Horse gear and parts of wagons

### *Hipposandals*

All five hipposandals from Vodice (Figs. 14; 15) are of the same shape, of nearly the same size and of a slightly different weight, depending on their massiveness. They belong to type 1 of the three types defined by Annabel K. Lawson and Xavier Aubert.<sup>162</sup> The hipposandals are dated, where the

<sup>159</sup> Manning 1985, 1, Fig. 1: 1 (the anvil from Vodice matches completely his description of the Italic type of anvils); Gaitzsch 1978, 16, fig. on pg. 4; Gaitzsch 1985, 179, Abb. 3 on pg. 192: type B, a list on pg. 201.

<sup>160</sup> Gaitzsch 1980, 341 No. 8, Taf. 2: 8, 365 No. 199, Taf. 43: 199a.

<sup>161</sup> Popescu 1997, 267 No. 545; Iaroslavschi 1997, 71, pl. 29: 3. The anvil is not dated.

<sup>162</sup> Lawson 1978, 133-135, Abb. 1 (here type 1 is confused with type 2: in the first row type 2 is depicted with a denotation

contexts of finds allow the dating at all, mostly to the time from the middle or second half of the 1st century to the end of the 4th century.<sup>163</sup> Younger pieces are not known, while only few pieces are dated to an earlier period (the Augustan period), for example from Magdalensberg.<sup>164</sup> A chronological development of the hipposandals according to types has not yet been studied. A cursory glance into some hoards of iron objects from the 3rd century that contain hipposandals reveals that all the hipposandals are of the so-called type 3 and none of the so-called type 1.<sup>165</sup> Therefore we can assume that in that time type 3 was probably in use and that type 1 is older.<sup>166</sup>

Finds of hipposandals are numerous, mostly in the north-western provinces of the Roman Empire, that is in northern *Gallia* (they are supposed to be a Gallic invention) and *Britannia*, but also in southern *Gallia* and provinces along the Rhine and Danube. On the other hand, they are very rare in the Mediterranean. It should be noted that the distribution also reflects the state of research and the attention paid to such objects.<sup>167</sup>

Iron hipposandals (the expression originates in the 19th century) were named by the Romans *solea ferrea*. There is a difference of opinion on their principal purpose and on the question of who wore them in the first place.<sup>168</sup> It seems most probable

type 1, in the second row, however, type 1 is depicted with a denotation type 2!); Manning 1985, 63-66, Fig. 16 (he added two more types to the existing typology); Junkelmann 1992, 88, Abb. 100.

<sup>163</sup> Lawson 1978, 136; Manning 1985, 65; Junkelmann 1992, 88.

<sup>164</sup> Dolenz 1998, 96-97 note 404, Taf. 22: M244.

<sup>165</sup> For example Mautern, a hoard of metal objects, dated to the 3rd century (Groh, Sedlmayer 2006, 512-525, Taf. 264: 1699/42); Straubing, a hoard of metal objects, buried most probably in the 3rd century (Kleim, Klumbach 1951, 38 Nos. 56-62, Taf. 43: 56-62); Welzheim, a hoard of iron objects, dated to the first half of the 3rd century (Mössle 1983, 374, Taf. 208: 1-3); Weißenburg, burying of the hoard is dated to the year 254 or the year 233 (Kellner, Zahlhaas 1993, 124 No. 94, 146, Taf. 107).

<sup>166</sup> I would like to thank Dr. Dragan Božič for a hint regarding the possible dating of both types of hipposandals.

<sup>167</sup> For example Lawson 1978, 136, Abb. 2 on pg. 135, Liste 1 on pg. 161-167; Junkelmann 1992, 88; Feugère, Thauré, Vienne 1992, 88-89 Nos. 171-179, with bibliography on new finds in South Gaul; Feugère, Tendille 1989, 152-153, fig. 109 (a complemented list and map of sites, made by A. Lawson); Garbsch 1986, 78-79, a list of finds from Bavaria; Manning 1985, 63-66; Ruprechtsberger 1975, 25-27, 36, Abb. 1 on pg. 26, finds from Upper Austria; Pöll, Nicolussi, Oeggl 1998, 63, Abb. 12: 3; Schaltenbrand Obrecht 1996, 156-157, 323 Nos. E 138-141, Taf. 44: 138-141; Müller 1982, 837, 168 Nos. 726, 727.

<sup>168</sup> Different interpretations and arguments for and against are presented in detail by Junkelmann 1992, 89; also Lawson 1978, 133.

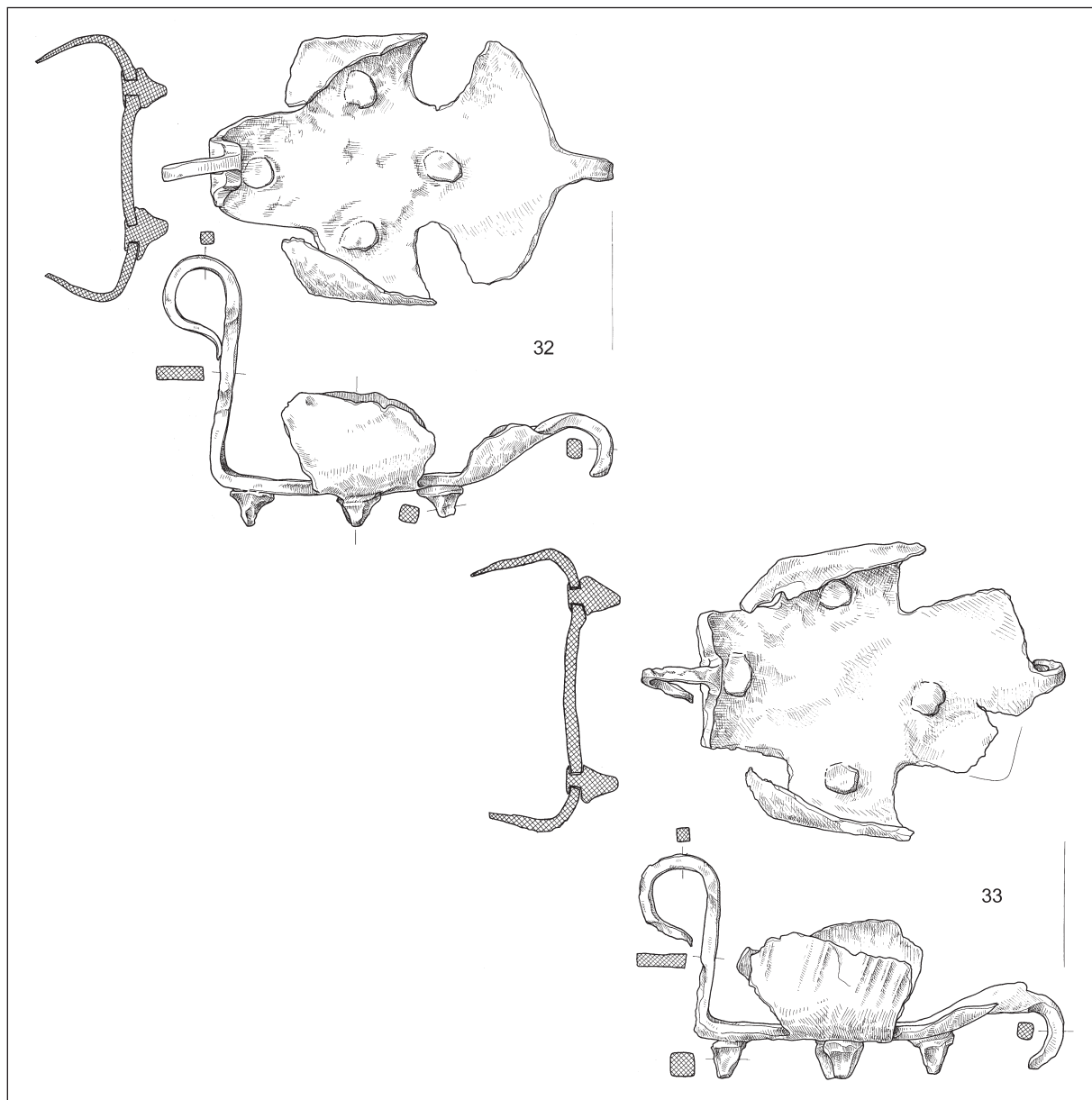

Fig. 14: Two hipposandals (32, 33) from Vodice. Iron. Scale = 1:3.  
 Sl. 14: Dve obušvali kopit (32, 33) z Vodice. Železo. M. = 1:3.

→  
 Fig. 15: Three hipposandals (34-36) from Vodice. Iron. Scale = 1:3.  
 Sl. 15: Tri obušvala kopit (34-36) z Vodice. Železo. M. = 1:3.

that the primary purpose of the hipposandals was to protect the hooves from wearing out and from sustaining injuries on hard ground (rock soil, rubble, gravel, hard pavement). The spikes or the grooves on the bottom face of the sole additionally protected the animal from slipping on slippery ground, snow and ice.<sup>169</sup> The second explanation,

<sup>169</sup> Lawson 1978, 133; Junkelmann 1992, 89; Ruprechtsberger 1975, 26; Manning 1985, 63.

that hipposandals were a veterinary device, holding in place on the injured hoof the dressing possibly with medicaments is rather less probable.<sup>170</sup> The use of an iron hipposandal in veterinary practice

<sup>170</sup> Lately, the interpretation has been tolerated, for example by Dixon, Southern 1992, 231, subscription to Fig. 82 on pg. 231. Arguments against: Lawson 1978, 133; Junkelmann 1992, 89. In connection with healing injuries, the ancient authors mention similar boots (*solea sparteae*) that were made of lighter materials, not iron (Walker 1973, 322).

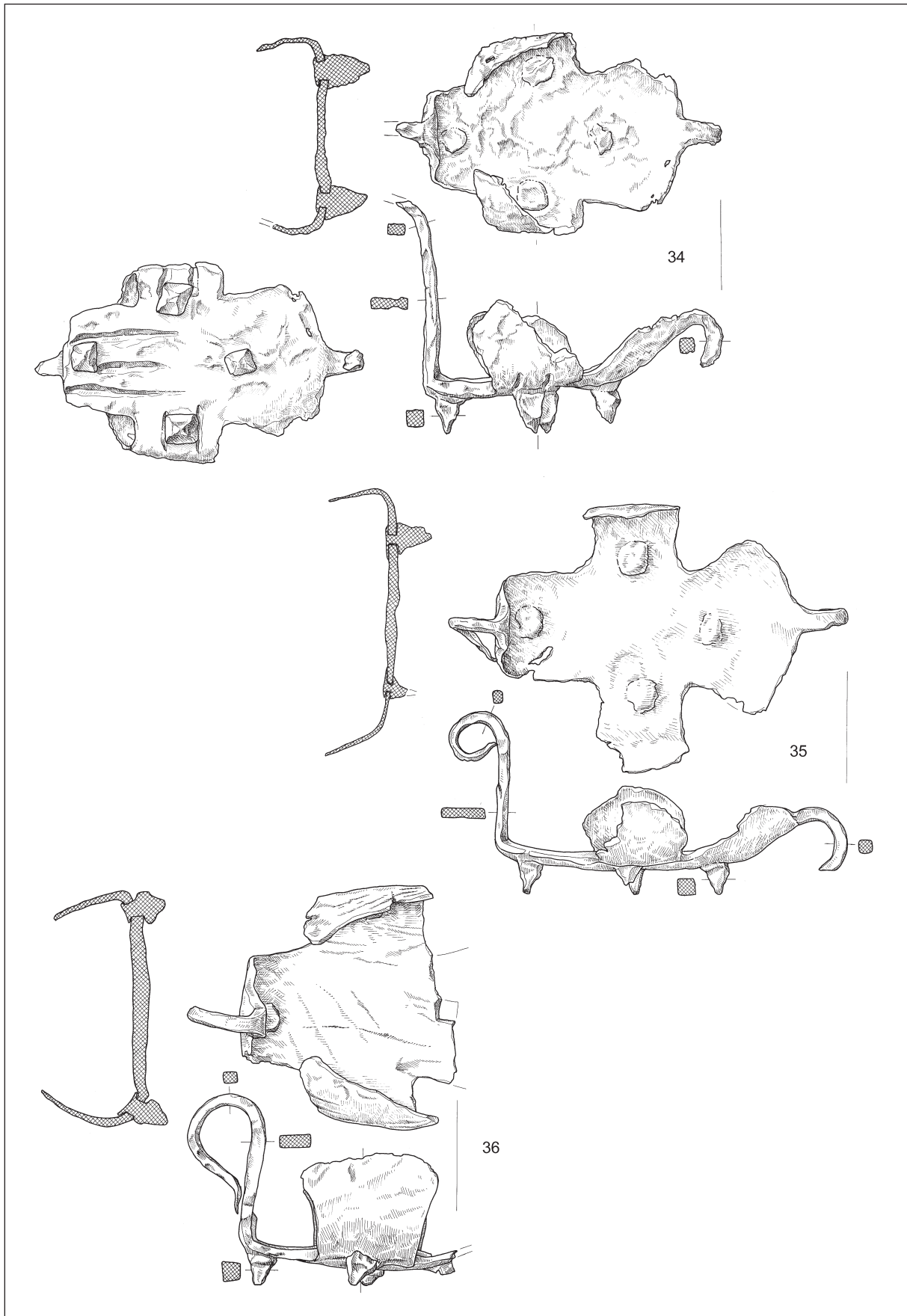

is mentioned only once in ancient written sources, in connection with the treatment of hip lameness in the horse. A hipposandal was put on the sound leg, thus slightly raising the horse and disburdening the lame leg of the horse's weight.<sup>171</sup>

Hipposandals were designed above all for draught and pack animals, only exceptionally for riding animals, as they enabled only awkward and slow walking. The draught and pack animals mostly consisted of mules, with some oxen and donkeys and rarely horses.<sup>172</sup> Hipposandals were put on hooves - having previously been wrapped in cloth - of mules and donkeys, rarely horses; for that reason they appear in different sizes.<sup>173</sup> For cattle, iron boots of a different form were designed, adapted to a cloven hoof, its parts booted separately for the sake of flexibility.<sup>174</sup>

In Slovenia, hipposandals are known also from other sites, for example, some older finds of type I have been published.<sup>175</sup>

#### *Two horseshoes*

The two horseshoes from Vodice (Fig. 16) are of the same form, the so-called form with crescent-shaped shanks (Ger. *Hufeisen mit Mondsichelruten*), next to the form with an undulating edge (Ger. *Hufeisen mit Wellenrand*) most frequently defined as a Roman form of horseshoe.<sup>176</sup>

Until recently, the long-lasting discussion on whether the Romans knew and used the horseshoes seemed unresolved, because horseshoes repeatedly appeared in apparent Roman (and more seldom in pre-Roman) layers and contexts.<sup>177</sup> Finally, Walter Drack convincingly refuted the existence of horseshoes in the pre-Roman and Roman period.<sup>178</sup> On the basis of excavations of a Roman road and above

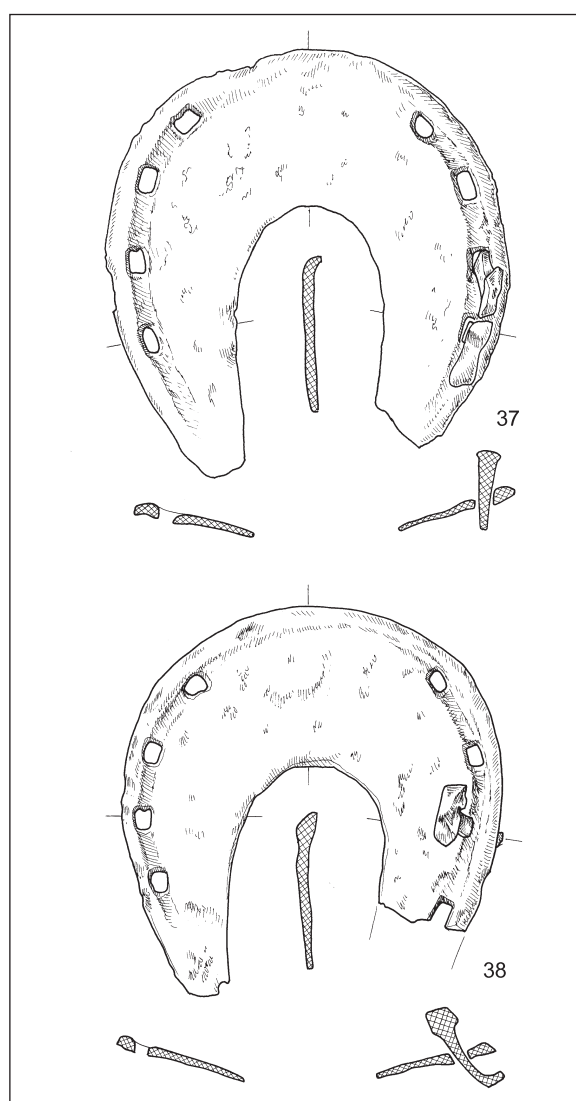

Fig. 16: The two horseshoes (37, 38) from Vodice. Iron. Scale = 1:2.

Sl. 16: Podkvi (37, 38) z Vodice. Železo. M. = 1:2.

<sup>171</sup> Walker 1973, 322-323.

<sup>172</sup> Toynbee 1973, 152, 161-162, 175-176, 185, 191, 194-195.

<sup>173</sup> Lawson 1978, 133; Junkelmann 1992, 90.

<sup>174</sup> Brouquier-Reddé 1991.

<sup>175</sup> Müllner 1900, Taf. LVI: 18; Petru 1972, 130 Nos. 56-58, t. XCI: 1-3; Horvat 1990, 289 No. 492, t. 24: 5; Müller 1982, 168 Nos. 726, 727.

<sup>176</sup> Junkelmann 1992, 93-94, Abb. 103/below.

<sup>177</sup> In favour of Roman horseshoes for example Lawson 1978, 137-140, Abb. 3 on pg. 138 (a distribution map), Liste 2 on pg. 167-172 (an extensive list); Ruprechtsberger 1975, 27-35; Manning 1985, 63 note 1; Garbsch 1986, 79, 82, permitting doubt; undecided Dixon, Southern 1992, 232-233; a review on their book Junkelmann 1993, 487; Müller 1982, 837-838, against the existence of Roman horseshoes; a detailed presentation of the discussion and arguments against Roman horseshoes in Junkelmann 1992, 92-98.

<sup>178</sup> Drack 1990.

it of a modern road in Oberwinterthur (*Vitudurum*) in Switzerland, he proved that the horseshoes had sunk into the Roman layers of the road later, as the Roman roadway was still in use in the 18th century.<sup>179</sup> Therefore, he determined the horseshoes typologically, comparing them with finds from the well-dated contexts on small castles of Switzerland, dated to the Middle Ages and modern times. The two forms of horseshoes most frequently recognized as Roman turned out to be typical of the Middle Ages and of the early modern times, respectively: horseshoes with an undulating edge were dated between the 10th and the 13th/14th centuries, horseshoes with crescent-shaped shanks between the 13th/14th

<sup>179</sup> *Ib.*, 204-205.



and the 15th/16th centuries. Horseshoes as a type of protection of hooves first appeared in the 10th or most early in the 9th century.<sup>180</sup> Because of the new finds of horseshoes, appearing repeatedly in the so-called Roman layers, the incontestable arguments of W. Drack still fail to convince everyone, and the doubts and argumentation of the opposite conclusions continue.<sup>181</sup>

According to W. Drack, we can date the horseshoes from Vodice into the period between the 13th/14th and the 15th/16th centuries.

### The bolt

The iron pin (*Pl. 4: 39*) of a cylindrical shape with a flat rectangular head is probably a bolt of a four-wheeled Roman wagon. It is the part of a wagon that was vertically stuck into the middle of the front axle, enabling a separable joining and rotation of the front part of the wagon (front axle and pole) apart from the rear (perch and rear axle) and upper part of the wagon. Because of the friction and loading exertion, the wooden parts of the wagon around the bolt were often strengthened with iron fittings of various shapes.<sup>182</sup> A pin, equal to the bolt, was also sometimes vertically stuck into the rear axle of a wagon and the wooden parts above it, but it was usually shorter because, unlike the bolt, it did not pierce the bottom of the wagon.<sup>183</sup> A pin of equal shape, but usually a little longer or much shorter (10 to 20 cm long), was on some wagons placed horizontally in front of the front axle, joining wooden parts on both sides of the pole,<sup>184</sup> or in equal place in front of the rear axle, joining wooden parts on both sides of the perch (*Fig. 17*).<sup>185</sup> Both kinds of pins being

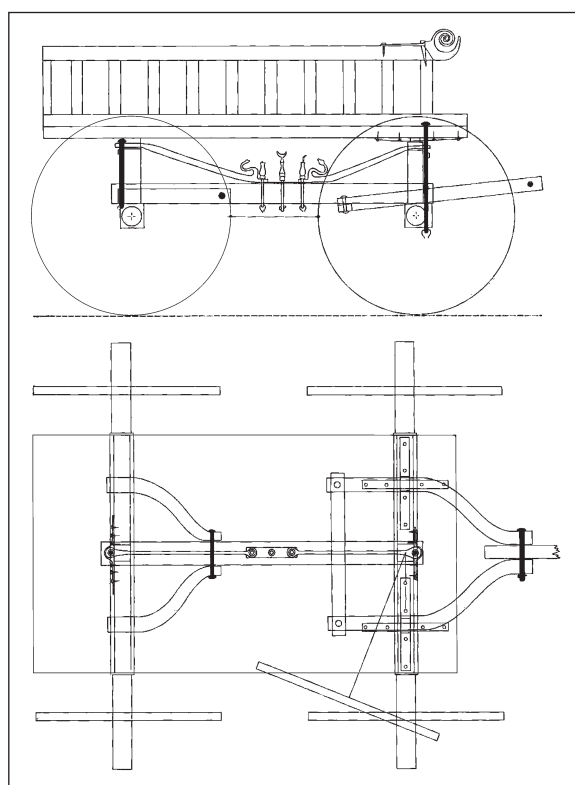

*Fig. 17:* Visy's reconstruction of a Roman wagon with a marked position of a bolt and similar pins (adapted from Visy 1993). *Sl. 17:* Visyjeva rekonstrukcija rimskega voza z označenimi legami sornika in njemu sorodnih zatičev (po Visiju 1993).

very rare and usually of a different length, it seems most probable that the pin from Vodice was a bolt, although there is no undisputed evidence of it. The two-wheeled carts had in place of a bolt a similar pin, but not necessarily round in the cross-section, as rotation around it was not needed.<sup>186</sup>

Bolts are 2-4 cm thick and 45 to 70 cm long, but they are often broken off at the end.<sup>187</sup> The entirely preserved piece from Vodice ranges among the longer ones with its 62.3 cm. The hole at the end was designed for a split pin.

It is difficult to date the bolts of Roman wagons with precision, as the construction of wagons had not changed much in the course of the Roman period. The Thracian *tumuli* of the Roman period containing such wagons, researched in detail and reconstructed by Ivan Venedikov, are for example dated to the time between the end of the 2nd century and the first half of the 4th century.<sup>188</sup> It

<sup>180</sup> *Ib.*, 206-207.

<sup>181</sup> For example Alföldy-Thomas 1993, 339-343, Taf. 548: G 43-45; 549: G 46-47; 550: G 48-50; undecided Höck 2003, 73 note 480, with bibliography on recent finds and discussion.

<sup>182</sup> Garbsch 1986, 61-63; Venedikov 1960, 8-29, above all 10-11 No. 7, 22 No. 34, 78-79, tabl. 1; 2: 5; 4: 9-11; 10; 13: 40; 59; 76-79; Visy 1993, 279-283, Taf. 435: F 133-136; 436: F 138-139; 437: F 137,140-142.

<sup>183</sup> Miniero 1987, 189 No. 29, 191, Fig. 18 on pg. 190; Visy 1993, Abb. 12 on pg. 292 and 293.

<sup>184</sup> Mráv 2005, 37-48, note 1 on pg. 21 - bibliography on reconstructions of Roman wagons; Venedikov 1960, 23 No. 41, tabl. 20: 33; 12: 37; 77-78 (the pin is 65 cm long, it has a hemispherical head, details are not visible, a 4 mm wide hole at the end is mentioned); Miniero 1987, 183 No. 11, Fig. 11 on pg. 184 (the pin is 73 cm long, it has a hemispherical head and a flattened end with an open ring); Visy 1993, 281-282, Abb. 12/below on pg. 293, Taf. 431: F 124-129 (the pins are 10 to 20 cm long).

<sup>185</sup> Visy 1993, Abb. 12/below on pg. 293.

<sup>186</sup> Venedikov 1960, 30-31 No. 85, tabl. 23: 72; 80. A four-edged pin of a two-wheeled cart from Telec in Bulgaria is tapering towards a bent pointed end.

<sup>187</sup> Garbsch 1986, 61; Visy 1993, 280, 282-283; Manning 1985, 126, Pl. 58: R6; Hübener 1973, 43, Taf. 15: 1,6,14,15.

<sup>188</sup> Venedikov 1960, 99-109.

is a burial rite that is dated, and it does not rule out the existence of such wagons outside graves in earlier and later times. A well preserved wagon, having a bolt and two other similar pins, was excavated in a Roman *villa* in *Stabiae*, buried beneath ashes at the eruption of Vesuvius in the year 79 AD.<sup>189</sup> Six similar short pins and ten long pins or bolts were found as a part of Alamanic booty sunken in the Rhein near Neupotz, most probably in the years 277/8, but they were supposedly in use in the middle decades of the 3rd century.<sup>190</sup> Only one piece from Neupotz has a head shaped as the bolt from Vodice, otherwise flat round or semi-spherical heads are the norm.<sup>191</sup>

In Slovenia, finds of pins, similar to bolts, are limited to the late Roman hoards of a similar composition as the group of finds from Vodice. Two pieces are contained in the hoard from Limberk above Velika Račna, dated to the years around 400 AD.<sup>192</sup>

### Others

The *awl* from Vodice (*Pl. 4: 40*) belongs, as for its shape, to a group of awls that did not change in the course of time and were most frequent in Late Antiquity. Such awls appear in graves, on settlements and in hoards. They vary in massiveness and were therefore differently interpreted as building materials, parts of furniture, fire-steel, steel for whetting knives or objects of unknown use.<sup>193</sup>

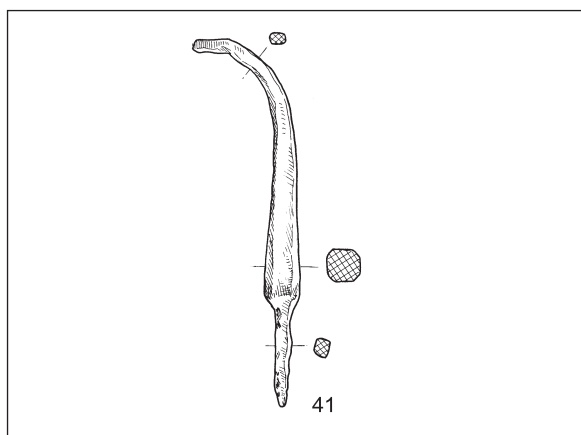

Fig. 18: The pointed object (41) from Vodice. Iron. Scale = 1:2.  
Sl. 18: Koničasti predmet (41) z Vodice. Železo. M. = 1:2.

<sup>189</sup> Miniero 1987, 171.

<sup>190</sup> Visy 1993, 326-327.

<sup>191</sup> *Ib.*, 282, Taf. 436: F 138.

<sup>192</sup> Bitenc, Knific 2001a, 32-33 Nos. 87: 29,38.

<sup>193</sup> A survey on such awls, with bibliography, in Klasinc 1999, 76-78, 24 No. 29, t. 4: 29; Murgelj 2000, 65-67, t. 12: 3,4.

The iron *pointed object* from Vodice (*Fig. 18*) has no perfect analogy among the reviewed Roman material, but it resembles the tanged arrowheads, square in the cross-section, not more precisely dated within the Roman Imperial period.<sup>194</sup>

### AN ATTEMPT AT RECONSTRUCTION OF THE HOARD (*Pl. 1-4*)

The presented group of finds from Vodice is already at first sight not a coherent set because it also comprises objects from the Middle Ages and modern times. A part of the group, however, according to the otherwise unreliable data presented by the collection-keeper J. J. Švajncer, is almost surely a late Roman hoard of iron tools. Which objects composed the hoard is not known any more. Timotej Knific from the National Museum of Slovenia finds the most probable congruent set to be a group of finds<sup>195</sup> presented to him by the keeper as a hoard at their first conversation. Apart from tools, the group comprised the anvil and the steelyard; the weapons and hipposandals were not among them. A list of hoards of iron tools found in Slovenia presents a somewhat lesser number of objects as the contents of the hoard from Vodice (two adzes, double-bladed adze, hoe, four axes, woodworking knife, knife), but these data are no more reliable as they originate from the collection-keeper as well.<sup>196</sup>

More exact and probably more reliable data on the place and context of the find exist only for the sword (*Fig. 3: 1*) and the two pieces of its scabbard (*Figs. 3: 2; 4; 5; cat. no. 3*), found in original position beside the sword.<sup>197</sup> These objects were found in the soil in a crevice on a small elevation or terrace south of the meadows of Vodice on the right side of the road, where the road begins to ascend from Vodice towards Lanišče (on the verge of the Roman settlement). The sword with the two pieces of its scabbard was found alone, but amid the neighbouring rocks some iron horseshoes, a spur and Roman bronze coins have also been found. A

<sup>194</sup> Radman-Livaja 2004, 56, 128 Nos. 64-68, t. 17: 64-68, with bibliography.

<sup>195</sup> For information on the probable composition of the hoard and on the unreliability of information on it, I would like to thank Dr. Timotej Knific who discussed the finds from Vodice on several occasions with their keeper, Janez J. Švajncer, and borrowed them to document and study them in the National Museum of Slovenia.

<sup>196</sup> Gaspari et al. 2000, 187.

<sup>197</sup> Švajncer 2003.

little further up from the place where the sword was found, "several iron axes ... and some other objects" were found. The mention that most probably refers to the hoard, namely that of the axes, proves that the sword was not comprised in the hoard.

Having been dated to later periods, we can immediately exclude the following from the hoard: the two horseshoes (*Fig. 16*) and probably the spearhead (*Fig. 8: 4*) and the hammer (*Fig. 12: 25*). According to the already presented data on the hoard, we must also exclude the hipposandals (*Figs. 14; 15*) and the weapons (the sword with two pieces of its scabbard [*Figs. 3-5; cat. no. 3*], the spearhead [*Fig. 8: 5*], the point [*Fig. 8: 6*], the two *plumbatae* [*Fig. 9*]). Weapons only exceptionally appear in the other similar hoards from Slovenia<sup>198</sup> and when they do, they are of a different character (for example a sword and a spearhead of eastern origin in the hoard from Limberk above Velika Račna).<sup>199</sup> Hipposandals have up to now not been known from hoards found on the territory of Slovenia, they are however present in some hoards elsewhere, but they do not belong to the type 1.<sup>200</sup> Which knives (*Fig. 10*), if any, were comprised in the hoard is not possible to discern. Ordinary knives are not known from hoards of iron tools from Slovenia, therefore we can also exclude them with some probability from the hoard from Vodice. It is hardly possible that the pointed object (*Fig. 18*) would have been comprised in the hoard, as it is possibly a piece of weapon and has no analogies in hoards of tools.

So the following objects are left as the supposed components of the hoard from Vodice (*Pl. 1-4*): a steelyard (*Pl. 1: 15; Fig. 11*), three wide axes (*Pl. 2: 16-18*), two axes (*Pl. 2: 19,20*), two adzes (*Pl. 3: 21,22*), a double-bladed adze (*Pl. 3: 23*), a hoe (*Pl. 3: 24*), a woodworking knife (*Pl. 3: 28*), a gimlet (*Pl. 3: 29*), a pair of compasses (*Pl. 4: 30*), an anvil (*Pl. 4: 31*), a bolt (*Pl. 4: 39*) and an awl (*Pl. 4: 40*). Wide axes,<sup>201</sup> axes, adzes,<sup>202</sup> hoes,

<sup>198</sup> A list of hoards of tools in Slovenia, with bibliography, in Gaspari et al. 2000, 187-188, Fig. 1. Some, at that time still unpublished, and some already published have later been presented in the catalogue of the exhibition Bitenc, Knific 2001, Nos. 14, 15, 87, 116, 117, 118, 140, 167, 168. A completed list of hoards, containing new finds and bibliography, in Božič 2005, 356-357.

<sup>199</sup> Bitenc, Knific 2001a; on the sword Pflaum 2000, 24 No. 97, 137-140, sl. 15, t. 15: 97.

<sup>200</sup> A list of late Roman hoards containing hipposandals is published in Groh, Sedlmayer 2006, 518.

<sup>201</sup> A list of wide axes in late Roman hoards in Slovenia in Božič 2005, 313. They all have an elongated back of the head, so they differ from the wide axes from Vodice.

<sup>202</sup> The double-bladed adze has no analogies in hoards found in Slovenia.

woodworking knives, gimlets with spoon bits, compasses, bolts, awls<sup>203</sup> and steelyards are the more or less usual components of hoards of tools from sites in Slovenia.<sup>204</sup> An anvil does not come as a surprise in a hoard of tools, although there are no other smith's tools in this hoard and although anvils have until now been an almost complete exception in such hoards.<sup>205</sup> However, as it is a type of anvil that appeared very early - in the 1st century - doubt arises as to whether the anvil from Vodice was in fact a part of the discussed late Roman hoard.

The hoard from Vodice in the described supposed composition contains types of objects that did not change much over a long period (except the steelyards), therefore it is difficult to date them more precisely only on the basis of their form. It is not possible to date the hoe, the pair of compasses and the bolt more precisely within the Roman Imperial period; the type of the anvil is known already from the 1st century, but it is not known for how long the type existed in the following centuries, the type of the steelyard is hypothetically dated to the 3rd century, with later substitution, however, indicating the use of the steelyard still in the 4th century; the axes are dated from the 3rd to the 6th century, the wide axes are dated to the 3rd and perhaps the 4th centuries, the woodworking knife is dated from the 3rd to the beginning of the 5th century, the two adzes, the double-bladed adze and the gimlet are late Roman (4th and the major part of the 5th century), the awl could be dated to the Late Antiquity (4th to the 6th century). If we conclude on the basis of other data on the site (noting that finds do not reach beyond the end of the 4th century) that the objects from the hoard are Roman and exclude the possibility of dating some of them (wide axes and awl) to the later part of the Late Antiquity (the end of the 5th century and the 6th century), then the youngest objects from the hoard are those dated on the basis of their form to the Late Roman period (adzes, double-bladed adze, gimlet). All in all, it is possible to date the burying of the hoard hypothetically to the 4th century, with regard to the steelyard possibly to the end of the 4th century.

The other presented Roman objects from Vodice not belonging to the supposed composition of the

<sup>203</sup> For example Celje (Gaspari et al. 2000, Fig. 7: 8).

<sup>204</sup> Cf. above the analysis of every single object.

<sup>205</sup> There are no anvils in the hoards, found in Slovenia. Elsewhere, a block-anvil of a different shape was found in Boljetin in Serbia as a part of a hoard dated to the 4th century (Popović 1988, 146-147, t. 29: 5).

hoard can be dated in a similar fashion - either inexactly to the Roman Imperial period (knives [Fig. 10], hipposandals [Figs. 14; 15], pointed object [Fig. 18]), or more precisely from the 3rd to the 5th century (the sword with the pieces of its scabbard [Figs. 3-5; cat. no. 3] to the 3rd century, the spearhead [Fig. 8: 5] to the 3rd and 4th centuries, the point [Fig. 8: 6] to the 4th century and the major part of the 5th century, *plumbatae* [Fig. 9] to the 4th and 5th centuries). On the one hand, these finds supplement the knowledge of the site connected with the traffic on the road leading over Hrušica (finds of parts of wagons, equipment of pack animals and tools), while on the other hand (finds of weapons) they indicate that the settlement was in some way included in the late Roman defence system *Claustra Alpium Iuliarum* with one of the two main fortresses right on the near Hrušica (*Ad Pirum*).

#### Acknowledgements

This article is a modified and complemented chapter of my thesis that I was working on in the years 2000 to 2004 as a "junior researcher" at the National Museum of Slovenia; the project was financed by the Ministry of Education, Science and Sport. I would like to thank Dr. Timotej Knific (National Museum of Slovenia) for enabling me to study the borrowed material from Vodice as well as for his practical and expert help. For a discussion of finds, exhaustive remarks on the text and instructions regarding the literature, particularly with reference to *plumbatae*, wide axes, double-bladed adzes, hoes and anvils, I would like to thank Dr. Dragan Božič (Institute of Archaeology, Scientific Research Centre of the SASA, Ljubljana). Drawings of finds were made in pencil by Uroš Stiškovski (1, 5-9, 13, 14, 16-30, 32-36, 40, 41), Ida Murgelj from the National Museum of Slovenia (4, 10-12, 31, 37-39) and Dragica Knific Lunder from the Institute of Archaeology (3, 15). All drawings were finished in ink by Dragica Knific Lunder. The map was made by Roman Hribar (National Museum of Slovenia) and Drago Valoh (Institute of Archaeology), plates by Drago Valoh. The English text was revised by Dr. Matej Accetto and by Dr. Agnes Pisanski Peterlin. I would like to thank all of them for their contribution and help. The preparation of the text was finished in spring 2006.

- ALFÖLDY-THOMAS, S. 1993, Anschnirungszubehör und Hufbeschläge von Zugtieren. - In: E. Künzl et al., *Die Alamannenbeute aus dem Rhein bei Neupotz. Plünderungsgut aus dem römischen Gallien*, Monographien des Römisch-Germanisches Zentralmuseums Mainz 34/1-4, 331-344.
- BARKER, Ph. 1979, The *plumbatae* from Wroxeter. - In: M. W. C. Hassal, R. Ireland (eds.), *De Rebus Bellicis*, BAR International Series 63/1, 97-99.
- BAVEC, U. 2001, *Mikroregionalno vrednotenje poselitve Velikih Malenc*. Master's thesis, Univerza v Ljubljani, Filozofska fakulteta, Oddelek za arheologijo. - Ljubljana.
- BENNETT, J. 1991, *Plumbatae* from Pitsunda (Pityus), Georgia, and some observations on their probable use. - *Journal of Roman Military Equipment Studies* 2, 59-63.
- vanden BERGHE, L. 1996, Some Roman military equipment of the first three centuries AD in Belgian museums. - *Journal of Roman Military Equipment Studies* 7, 59-95.
- BIBORSKI, M. 1994, Römische Schwerter im Gebiet des europäischen Barbaricum. - In: C. van Driel-Murray (ed.), *Military Equipment in Context. Proceedings of the Ninth International Roman Military Equipment Conference, Leiden, 1994*, *Journal of Roman Military Equipment Studies* 5, 169-197.
- BISHOP, M. C. and J. C. N. COULSTON 1993, *Roman Military Equipment from the Punic Wars to the fall of Rome*. - London.
- BITENC, P. 1997, *Rimskodobne in srednjeveške sekire iz Ljubljane*. Seminarska naloga, Univerza v Ljubljani, Filozofska fakulteta, Oddelek za arheologijo. - Ljubljana.
- BITENC, P. 2001, Zakladna najdba orodja. - In: Bitenc, Knific 2001, 14, cat. no. 14.
- BITENC, P. 2001a, Sekiri. - In: Bitenc, Knific 2001, 14, cat. no. 13.
- BITENC, P. 2001b, Orodje in zvonec. - In: Bitenc, Knific 2001, 40, 41, cat. no. 110.
- BITENC, P. and T. KNIFIC (eds.) 2001, *Od Rimljanov do Slovanov. Predmeti*. - Ljubljana.
- BITENC, P. and T. KNIFIC 2001a, Zakladna najdba. - In: Bitenc, Knific 2001, 32-33, cat. no. 87.
- BORHY, L. 1989, Ein eisernes Dosenortband mit Messingtauschierung aus Pannonien. - *Communicationes Archaeologicae Hungariae* 1989, 129-140.
- BOŽIČ, D. 2005, Die spätrömischen Hortfunde von der Gora oberhalb von Polhov Gradec. - *Arheološki vestnik* 56, 293-368.
- BROUQUIER-REDDÉ, V. 1991, La sandale en fer du boeuf romain ou bousandale. - *Saalburg Jahrbuch* 46, 41-56.
- BUORA, M. 1997, Nuovi studi sulle *plumbatae* (= *mattiobarbuli*?). A proposito degli stanziamenti militari nell'Ilirico occidentale e nell'Italia orientale nel IV e all'inizio del V secolo. - *Aquileia Nostra* 68, 237-246.
- CHRISTODOULOU, D. N. 2001-2002, Military equipment from the site of the Emperor Galerius' palace in Gamzigrad/Serbia. - *Journal of Roman Military Equipment Studies* 12-13, 29-34.
- CIGLENEČKI, S. 1990, K problemu datacije nastanka rimskodobnih višinskih utrd v jugovzhodnoalpskem prostoru (Zum Datierungsproblem der Entstehung der römerzeitlichen Höhenbefestigungen im Südostalpenraum). - *Arheološki vestnik* 41, 147-176.
- CIGLENEČKI, S. 1994, Poznoantična naselbina Tonovcov grad pri Kobaridu. - *Kronika* 42/1, 1-14.
- CIGLENEČKI, S. 1994a, Höhenbefestigungen als Siedlungsgrundeinheit der Spätantike in Slowenien. - *Arheološki vestnik* 45, 239-266.
- DEGEN, R. 1992, *Plumbatae*. Wurfgeschosse der Spätantike. - *Helvetica Archaeologica* 92, 139-147.
- DIXON, K. R. and P. SOUTHERN 1992, *The Roman Cavalry. From the First to the Third Century AD*. - London.
- DOLENZ, H. 1998, *Eisenfunde aus der Stadt auf dem Magdalensberg*. - *Kärntner Museumsschriften* 75, Archäologische Forschungen zu den Grabungen auf dem Magdalensberg 13.

- DRACK, W. 1990, Hufeisen - entdeckt in, auf und über der römischen Straße in Oberwinterthur (Vitodurum). Ein Beitrag zur Geschichte des Hufeisens. - *Bayerische Vorgeschichtsblätter* 55, 191-239.
- EAGLE, J. 1989, Testing plumbatae. - In: C. van Driel-Murray (ed.), *Roman Military Equipment: the Sources of Evidence. Proceedings of the Fifth Roman Military Equipment Conference*, BAR International Series 476, 247-253.
- FEUGÈRE M: 2004 *Les armes des Romains de la République à l'Antiquité tardive* Paris:
- FEUGÈRE M: and C: TENDILLE 2090 Les objets métalliques. In J: L: Fiches Jed: *Loppidum d'Ambrussum et son territoire* Monographies C:R:A: 3 254 2 6:
- FEUGÈRE M: M: THAURÉ and G: VIENNE )eds: 2003 *Les objets en fer dans les collections du musée archéologique de Saintes* 1<sup>er</sup> XV<sup>e</sup> siècle Saintes:
- FRANKEN, N. 1993, Zur Typologie antiker Schnellwaagen. - *Bonner Jahrbücher* 193, 69-120.
- FRELIH, M. 1985, Kalce. - *Varstvo spomenikov* 27, 227-228.
- FRELIH, M. 1988, Komunikacijski sistem v prazgodovini in antiki na primeru Logaške kotline. - In: *Mladinski raziskovalni tabor Logatec '88. Zbornik poročil raziskovalnih skupin*, 10-51, Logatec.
- GAITZSCH, W. 1978, *Römische Werkzeuge*. - Kleine Schriften zur Kenntnis des römischen Besetzungsgeschichte Südwestdeutschlands 19.
- GAITZSCH, W. 1980, *Eiserne römische Werkzeuge. Studien zur römischen Werkzeugkunde in Italien und den nördlichen Provinzen des Imperium Romanum*. - BAR International Series 78.
- GAITZSCH, W. 1985, Werkzeuge und Geräte in der römischen Kaiserzeit. Eine Übersicht. - In: H. Temporini (ed.), *Aufstieg und Niedergang der Römischen Welt* 2/12.3, 170-204, Berlin, New York.
- GARBSCH, J. 1966, *Der Moosberg bei Murnau*. - Münchner Beiträge zur Vor- und Frühgeschichte 12.
- GARBSCH, J. 1986, *Mann und Roß und Wagen. Transport und Verkehr im antiken Bayern*. - Ausstellungskataloge der Prähistorischen Staatssammlung 13.
- GARBSCH, J. 1988, Wagen oder Waagen? - *Bayerische Vorgeschichtsblätter* 53, 191-222.
- GASPARI, A. 2001, Zakladna najdba orodja. - In: Bitenc, Knific 2001, 58, cat. no. 168.
- GASPARI, A., M. GUŠTIN, I. LAZAR and B. ŽBONA TRKMAN 2000, Late Roman tool finds from Celje, Gradišče at Zbelovska gora and Sv. Pavel above Vrtovin (Slovenia). - In: M. Feugère, M. Guštin (eds.), *Iron, Blacksmiths and Tools. Ancient European Crafts. Acts of the Instrumentum Conference at Podsreda (Slovenia) in April 1999*, Monographies Instrumentum 12, 187-203.
- GIESLER, U. 1981, Katalog der Kleinfunde. - In: Th. Ulbert (ed.), *Ad Pirum (Hrušica). Spätromische Passbefestigung in den Julischen Alpen. Der deutsche Beitrag zu den Slowenisch-Deutschen Grabungen 1971-1973*, Münchner Beiträge zur Vor- und Frühgeschichte 31, 53-127.
- GROH, S. and H. SEDLMAYER 2006, *Forschungen im Vicus Ost von Mautern-Favianis. Die Grabungen der Jahre 1997-1999*. - Der römische Limes in Österreich 44.
- GUŠTIN, M. 1973, Kronologija notranjske skupine (Cronologia del gruppo preistorico della Notranjska [Carniola Interna]). - *Arheološki vestnik* 24, 461-506.
- GUŠTIN, M. 1979, *Notranjska. K začetkom železne dobe na severnem Jadranu (Notranjska. Zu den Anfängen der Eisenzeit an der nördlichen Adria)*. - Katalogi in monografije 17.
- HAGENDORN, A., H. W. DOPPLER, A. HUBER, H. HÜSTER PLOGMANN, S. JACOMET, Ch. MEYER-FREULER, B. PFÄFFLI and J. SCHIBLER 2003, *Zur Frühzeit von Vindonissa. Auswertung der Holzbauten der Grabung Windisch-Breite 1996-1998*. - Veröffentlichungen der Gesellschaft pro Vindonissa 18.
- HENNING, J. 1987, Eisenverarbeitungswerkstätten im unteren Donaugebiet zwischen Spätantike und Frühmittelalter. - *Zeitschrift für Archäologie* 21/1, 59-73.
- HÖCK, A. 2003, *Archäologische Forschungen in Teriola I. Die Rettungsgrabungen auf dem Martinsbühel bei Zirl von 1993-1997. Spätromische Befunde und Funde zum Kastell*. - Fundberichte aus Österreich, Materialhefte A 14.
- HOFFILLER, V. 1912, Oprema rimskoga vojnika u prvo doba carstva. - *Vjesnik hrvatskoga arheološkoga društva n. s.* 12, 16-123.
- HOFFILLER, V. and B. SARIA 1938, *Antike Inschriften aus Jugoslavien*. - Zagreb.
- HORVAT, J. 1990, *Nauportus (Vrhniko)*. - Dela 1. razreda SAZU 33.
- HÜBENER, W. 1973, *Die römischen Metallfunde von Augsburg-Oberhausen. Ein Katalog*. - Materialhefte zur bayerischen Vorgeschichte 28.
- HUBER, A. 2003, Die Funde aus Eisen, Bronze, Blei und Bein. - In: A. Hagendorn et al., *Zur Frühzeit von Vindonissa. Auswertung der Holzbauten der Grabung Windisch-Breite 1996-1998*, Veröffentlichungen der Gesellschaft pro Vindonissa 18, 373-441.
- HUNDT, H.-J. 1953, Die spätromischen eisernen Dosenortbänder. - *Saalburg Jahrbuch* 12, 66-79.
- HUNDT, H.-J. 1955, Nachträge zu den römischen Ringknäufschwertern, Dosenortbändern und Miniaturschwertanhängern. - *Saalburg Jahrbuch* 14, 50-59.
- IAROSLAVSCHI, E. 1997, *Tehnica la daci*. - Bibliotheca Musei Napocensis 15.
- ILKJÆR J: 200 *Illerup Ådal 2 3: Die Lanzen und Speere*: Jutland Archaeological Society Publications 36-2 3:
- ILKJÆR J: 2005 *Das Mooropfer von Illerup Ådal. Der Stand der Bearbeitung im Jahr 1994*. - In: C. von Carnap-Bornheim (ed.), *Beiträge zu römischer und barbarischer Bewaffnung in den ersten vier nachchristlichen Jahrhunderten. Akten des 2. Internationalen Kolloquiums in Marburg a. d. Lahn, 20. bis 24. Februar 1994*, Veröffentlichung des Vorgeschichtlichen Seminars Marburg, Sonderband 8, 233-248.
- IRELAND, R. (ed.) 1979, *Anonymi auctoris libellus De Rebus Bellicis*. - In: M. W. C. Hassall, R. Ireland (eds.), *De Rebus Bellicis*, BAR International Series 63/2.
- JUNKELMANN, M. 1992, *Die Reiter Roms. Teil 3: Zubehör, Reitweise, Bewaffnung*. - Kulturgeschichte der antiken Welt 53.
- JUNKELMANN, M. 1993, Karen R. Dixon und Pat Southern, *The Roman Cavalry*. - *Bonner Jahrbücher* 193, 486-488.
- KACZANOWSKI, P. 1992, *Importy broni rzymskiej na obszarze europejskiego barbaricum*. - Uniwersytet Jagielloński, Rozprawy habilitacyjne 244.
- KASPRZYK, M. 2004, Militaires et fonctionnaires de l'Antiquité tardive à Escolives-Sainte-Camille (Yonne) ? - *Revue Archéologique de l'Est* 53, 239-252.
- KAUFMANN-HEINIMANN, A. 1998, *Götter und Lararien aus Augusta Raurica*. - Forschungen in Augst 26.
- KEIM, J. and H. KLUMBACH 1951, *Der römische Schatzfund von Straubing*. - Münchner Beiträge zur Vor- und Frühgeschichte 3.
- KELLNER, H.-J. and G. ZAHLHAAS 1983, *Der römische Schatzfund von Weißenburg*. - München, Zürich.
- KELLNER, H.-J. and G. ZAHLHAAS 1993, *Der Römische Tempelschatz von Weißenburg i. Bay.* - Mainz am Rhein.
- KLASINC, R. 1999, *Gradec pri Veliki Strmici v obdobju preseljevanja ljudstev*. Diploma thesis, Univerza v Ljubljani, Filozofska fakulteta, Oddelek za arheologijo. - Ljubljana.
- KNIFIC, T. 1979, *Vranje pri Sevnici. Drobne najdbe z Ajdovskega gradca (leto 1974) (Vranje bei Sevnica. Kleinfunde aus Ajdovski gradec [J. 1974])*. - *Arheološki vestnik* 30, 732-785.
- KNIFIC, T. 2001, *Železno orodje, železna ključa in kamniti brusi*. - In: Bitenc, Knific 2001, 52, cat. no. 146.

- KOCH, U. 1984, *Der Runde Berg bei Urach V. Die Metallfunde der frühgeschichtlichen Perioden aus den Plangrabungen 1967-1981*. - Heidelberger Akademie der Wissenschaften, Kommission für Alamannische Altertumskunde, Schriften 10.
- KOLIAS, T. G. 1988, *Byzantinische Waffen. Ein Beitrag zur byzantinischen Waffenkunde von den Anfängen bis zur lateinischen Eroberung*. - Byzantina Vindobonensia 17.
- KOROŠEC, P. 1982, Predjama konec 4. do sredine 5. stoletja (Predjama vom Ende des 4. bis zur Mitte des 5. Jahrhunderts). - *Arheološki vestnik* 33, 84-114.
- KOS, P. 1986, *The Monetary Circulation in the Southeastern Alpine Region ca. 300 B.C.-A.D. 1000*. - Situla 24.
- KOS, P. and A. ŠEMROV 1995, *Die Fundmünzen der römischen Zeit in Slowenien* 3. - Berlin.
- KREMPUŠ, R. 2000, Krvavica bei Vransko in Slowenien, Höhengsiedlung des 3. bis 6. Jahrhunderts. - In: M. Feugère, M. Guštin (eds.), *Iron, Blacksmiths and Tools. Ancient European Crafts. Acts of the Instrumentum Conference at Podsreda (Slovenia) in April 1999*, Monographies Instrumentum 12, 209-231.
- KÜNZL, E. 1993, Römerzeitliche Waffen. - In: E. Künzl et al., *Die Alamannenbeute aus dem Rhein bei Neupotz. Plünderungsgut aus dem römischen Gallien*, Monographien des Römisch-Germanisches Zentralmuseums Mainz 34/1-4, 75-81.
- LAWSON, A. K. 1978, Studien zum römischen Pferdegeschirr. - *Jahrbuch des Römisch-Germanischen Zentralmuseums Mainz* 25, 131-172.
- LEBEN, F. and Z. ŠUBIC 1990, Poznoantični kastel Vrh Brsta pri Martinj Hribu na Logaški planoti (Das spätantike Kastell Vrh Brsta bei Martinj Hrib auf dem Karstplateau von Logatec). - *Arheološki vestnik* 41, 313-354.
- LENZ-BERNHARD, G. 1986, Ein Dosenortband aus der villa rustica Ladenburg "Ziegelscheuer". - *Archäologische Nachrichten aus Baden* 36, 32-42.
- LÖNSTRUP, J. 1986, Das zweischneidige Schwert aus der jüngeren römischen Kaiserzeit im freien Germanien und im römischen Imperium. - In: *Studien zu den Militärgrenzen Roms* 3/13. *Internationaler Limeskongreß Aalen 1983. Vorträge*, Forschungen und Berichte zur Vor- und Frühgeschichte in Baden-Württemberg 20, 747-749.
- MANNING, W. H. 1985, *Catalogue of the Romano-British iron tools, fittings and weapons in the British Museum*. - London.
- MARCHANT, D. 1990, Roman weapons in Great Britain, a case study: spearheads, problems in dating and typology. - *Journal of Roman Military Equipment Studies* 1, 1-6.
- MARTIN-KILCHER, S. 1985, Ein silbernes Schwertortband mit Niellodekor und weitere Militärfunde des 3. Jahrhunderts aus Augst. - *Jahresberichte aus Augst und Kaiseraugst* 5, 147-203.
- MENGHIN, W. 1983, *Das Schwert im Frühen Mittelalter. Chronologisch-typologische Untersuchungen zu Langschwertern aus germanischen Gräbern des 5. bis 7. Jahrhunderts n. Chr.* - Wissenschaftliche Beibände zum Anzeiger des Germanischen Nationalmuseums 1.
- MINIERO, P. 1987, Studio di un carro romano dalla Villa c. d. di Arianna a Stabia. - *Mélanges de l'École française de Rome, Antiquité* 99/1, 171-209.
- MLINAR, I. 1965, Iz rimskega Ozidja v Krajini (Aus dem römischen Ozidje in Krajina). - *Časopis za zgodovino in narodopisje*, n. v. 1, 64-74.
- MÖSSLE, Th. 1983, Welzheim. - *Fundberichte aus Baden-Württemberg* 8, 374-375.
- MRÁV, Zs. 2005, Die Deichselmanschette. Zugarmkonstruktion bei römischen Wagen. - *Archaeologiai Értesítő* 130, 21-51.
- MÜLLER, R. 1982, *A mezőgazdasági vaseszközök fejlődése Magyarországon a késővaszkortól a törökök végéig (Die Entwicklung der eisernen Agrargeräte in Ungarn von der Spätisenzeit bis zum Ende der Türkenherrschaft)*. - Zalai Gyűjtemény 19/1-2.
- MÜLLNER, A. 1900, *Typische Formen aus den archäologischen Sammlungen des krainischen Landesmuseums "Rudolfinum" in Laibach in photographischen Reproduktionen*. - Ljubljana.
- MURGELJ, I. 2000, *Kovinsko gradivo z Ajdovščine nad Rodikom*. Diploma thesis, Univerza v Ljubljani, Filozofska fakulteta, Oddelek za arheologijo. - Ljubljana.
- MUTZ, A. 1983, *Römische Waagen und Gewichte aus Augst und Kaiseraugst*. - Augster Museumshefte 6.
- MUTZ, A. 1988, Eine spätantik-byzantinische Schnellwaage. - *Bayerische Vorgeschichtsblätter* 53, 223-232.
- OLDENSTEIN, J. 1976, Zur Ausrüstung römischer Auxiliareinheiten. - *Bericht der Römisch-Germanischen Kommission* 57, 49-284.
- OSMUK, N. 1976, Nove antične najdbe v Povirju (Nuove scoperte dell'età romana a Povir). - *Goriški letnik* 3, 70-87.
- PETROVITSCH, H. 2006, *Legio II Italica*. - Forschungen in Lauriacum 13.
- PETRU, P. 1976, *Zaton antike v Sloveniji*. - Ljubljana.
- PETRU, S. 1972, *Emonske nekropole (odkrite med leti 1635-1960)*. - Katalogi in monografije 7.
- PETRU, S. 1975, Hrušica. - In: *Arheološka najdišča Slovenije*, 122-123, Ljubljana.
- PETRU, S. and P. PETRU 1978, *Neviodunum (Drnovo pri Krškem)*. - Katalogi in monografije 15.
- PFLAUM, V. 2000, *Claustra Alpium Iuliarum in barbari. Najdbe poznorimske vojaške opreme in orožja ter sočasne zgodnje barbarske najdbe na ozemlju današnje Slovenije*. Master's thesis, Univerza v Ljubljani, Filozofska fakulteta, Oddelek za arheologijo - Ljubljana.
- PFLAUM, V. 2001, Plumbata. - In: Bitenc, Knific 2001, 22, cat. no. 46.
- PFLAUM, V. 2001a, Plumbata. - In: Bitenc, Knific 2001, 22-23, cat. no. 47.
- PFLAUM, V. 2001b, Osti kopij in plumbata. - In: Bitenc, Knific 2001, 23-24, cat. no. 51.
- PIETSCH, M. 1983, Die römischen Eisenwerkzeuge von Saalburg, Feldberg und Zugmantel. - *Saalburg Jahrbuch* 39, 5-132.
- PLEINER, R. 1967, Die Technologie des Schmiedes in der großmährischen Kultur. - *Slovenská archeológia* 15/1, 77-188.
- POHANKA, R. 1986, *Die eisernen Agrargeräte der Römischen Kaiserzeit in Österreich. Studien zur römischen Agrartechnologie in Rätien, Noricum und Pannonien*. - BAR International Series 298.
- PÖLL, J., K. NICOLUSSI and K. OEGGL 1998, Die römische Reichsstraße Via Claudia Augusta bei Lermoos (Tirol). Ergebnisse der archäologischen, dendrochronologischen und palynologischen Untersuchungen. - *Archäologie Österreichs* 9/1, 55-70.
- POLLAK, M. 2006, *Stellmacherei und Landwirtschaft: Zwei römische Materialhorte aus Mannersdorf am Leithagebirge, Niederösterreich*. - Fundberichte aus Österreich, Materialhefte A/16.
- PONSTINGL, U. 1986, Eisenschwert. - *Carnuntum Jahrbuch* 1986, 273-274 (Abb. 32).
- POPESCU, G. A. (ed.) 1997, *I Daci*. - Milano.
- POPOVIĆ, I. 1988, *Antičko oruđe od gvožđa u Srbiji (Les outils antiques en fer de Serbie)*. - Monografije 5.
- PRÖTTEL, Ph. M. 1988, Zur Chronologie der Zwiebelknopffibel. - *Jahrbuch des Römisch-Germanischen Zentralmuseums Mainz* 35/1, 347-372.
- PRÖTTEL, Ph. M. 1996, *Mediterrane Feinkeramikimporte des 2. bis 7. Jahrhunderts n. Chr. im oberen Adriaaraum und in Slowenien*. - Kölner Studien zur Archäologie der römischen Provinzen 2.
- RADMAN-LIVAJA, I. 2004, *Militaria Sisciensia. Nalazi rimske vojne opreme iz Siska u fundusu Arheološkoga muzeja u Zagrebu*. - Katalogi i monografije Arheološkog muzeja u Zagrebu 1.
- RALD, U. 1994, The Roman swords from Danish bog finds. - In: C. van Driel-Murray (ed.), *Military Equipment in Context*.

- Proceedings of the Ninth International Roman Military Equipment Conference, Leiden, 1994*, Journal of Roman Military Equipment Studies 5, 227-241.
- REES, S. E. 1979, *Agricultural Implements in Prehistoric and Roman Britain*. - BAR British Series 69.
- RIEDL, E. and O. CUNTZ 1909, Uranje in Steiermark, römische Bauten und Grabmäler. - *Jahrbuch für Altertumskunde* 3, 1-34.
- RUPRECHTSBERGER, E. 1975, Hipposandalen und Hufeisen. Die Hufeisen aus dem Ennser Museum. - *Jahrbuch des Oberösterreichischen Musealvereines* 120/1, 25-36.
- SAGADIN, M. 2000, Late Antique wood-working tools from Grdov hrib near Kamnik (Slovenia). - In: M. Feugère, M. Guštin (eds.), *Iron, Blacksmiths and Tools. Ancient European Crafts. Acts of the Instrumentum Conference at Podsreda (Slovenia) in April 1999*, Monographies Instrumentum 12, 205-208.
- SAGADIN, M. 2000a, Poznoantični sodar z Grdavovega hriba pri Radomljah (Late Roman barrel maker from Grdov hrib near Radomlje). - *Annales* 10/2 (22), 559-563.
- SAGADIN, M. 2001, Zakladna najdba. - In: Bitenc, Knific 2001, 14-15, cat. no. 15.
- SARIA, B. 1924, Zur Geschichte der Provinz Dacien. - In: M. Abramić, V. Hoffiller (eds.), *Bulićev zbornik*, 249-252, Zagreb, Split.
- SCHALTENBRAND OBRECHT, V. 1996, Die Eisenfunde. - In: E. Deschler-Erb (ed.), *Beiträge zum römischen Oberwinterthur - VITUDURUM 7. Ausgrabungen im Unteren Bühl. Die Funde aus Metall. Ein Schrank mit Lararium des 3. Jahrhunderts*, Monographien der Kantonsarchäologie Zürich 27, 141-228.
- SCHULZE-DÖRRLAMM, M. 1985, Germanische Kriegergräber mit Schwertbeigabe in Mitteleuropa aus dem späten 3. Jahrhundert und der ersten Hälfte des 4. Jahrhunderts n. Chr. - *Jahrbuch des Römisch-Germanischen Zentralmuseums Mainz* 32, 509-569.
- SHERLOCK, D. 1979, Plumbatae - a note on the method of manufacture. - In: M. W. C. Hassall, R. Ireland (eds.), *De Rebus Bellicis*, BAR International Series 63/1, 101-102.
- SLAPŠAK, B. 1996, Rimska doba. - In: *Enciklopedija Slovenije* 10, 219-225, Ljubljana.
- SLAPŠAK, B. 1997, Starejša zgodovina Rodika (The Early History of Rodik). - In: M. Pregelj (ed.), *Rodik med Brkini in Krasom*, 19-64, Koper.
- SLAPŠAK, B. 1999, Slovenski Kras v poznejši prazgodovini in v rimski dobi. - In: A. Kranjc, V. Likar, M. Žalik Huzjan (eds.), *Kras. Pokrajina, življenje, ljudje*, 145-163, Ljubljana.
- STICOTTI, P. 1951, *Inscriptiones Italiae, Volumen X - Regio X, Fasciculus IV*. - Tergeste-Roma.
- STIGLITZ, H. 1986, Auxiliarkastell - Carnuntum. - *Carnuntum Jahrbuch* 1986, 193-225.
- STRMČNIK, M. 1997, Mariborsko - bistriško območje v poznorimski dobi (Der Raum Maribor und Bistrica in spätrömischer Zeit). - *Arheološki vestnik* 48, 269-288.
- ŠAŠEL, J. 1975, Podutik. - In: *Arheološka najdišča Slovenije*, 199, Ljubljana.
- ŠEMROV, A. 1998, *Die Fundmünzen der römischen Zeit in Slowenien* 4. - Berlin.
- ŠVAJNCER, J. J. 2003, Spatha izpod Hrušice. - *Vojnogodovinski zbornik* 12, 3-7.
- TOYNBEE, J. M. C. 1973, *Animals in Roman Life and Art*. - New York.
- ULBERT, G. 1974, Straubing und Nydam. Zu römischen Langschwertern der späten Limeszeit. - In: G. Kossack, G. Ulbert (eds.), *Studien zur vor- und frühgeschichtlichen Archäologie. Festschrift für Joachim Werner zum 65. Geburtstag* 1, Münchner Beiträge zur Vor- und Frühgeschichte, Ergänzungsband 1/1, 197-216.
- ULBERT, Th. (ed.) 1981, *Ad Pirum (Hrušica). Spätrömische Passbefestigung in den Julischen Alpen. Der deutsche Beitrag zu den Slowenisch-Deutschen Grabungen 1971-1973*. - Münchner Beiträge zur Vor- und Frühgeschichte 31.
- VALIČ, A. 1985, Ajdna nad Potoki. - *Varstvo spomenikov* 27, 265-272.
- VALIČ, A. 1997, Arheološki drobci vojaških prvin pozne rimske dobe na Gorenjskem (Archäologische Funde von Militärelementen der spätrömischen Zeit in Gorenjsko). - *Arheološki vestnik* 48, 261-268.
- VENEDIKOV, I. 1960, *Trakijskata kolesnica*. - Sofija.
- VISY, Zs. 1993, Wagen und Wagenteile. - In: E. Künzl et al., *Die Alamannenbeute aus dem Rhein bei Neupotz. Plünderungsgut aus dem römischen Gallien*, Monographien des Römisch-Germanisches Zentralmuseums Mainz 34/1-4, 257-327.
- VÖLLING, Th. 1991, Plumbata - Mattiobarbulus - MAPTZOBAP-BOYLON? - *Archäologischer Anzeiger* 1991/2, 287-298.
- VOLPERT, H.-P. 1997, Die römische Wassermühle einer villa rustica in München-Perlach. - *Bayerische Vorgeschichtsblätter* 62, 243-278.
- WALKER, R. E. 1973, Roman Veterinary Medicine. - In: J. M. C. Toynbee, *Animals in Roman Life and Art*, 301-343, New York.
- WHITE, K. D. 1967, *Agricultural Implements of the Roman World*. - Cambridge.

## Domnevna poznorimska zakladna najdba orodja in hitre tehtnice z Vodice pri Kalcah

### UVOD

Vojni muzej v Logatcu hrani skupino predvsem železnih večinoma rimskodobnih predmetov, ki jih je na arheološkem najdišču Vodice pri Kalcah ob pomoči detektorja kovin našel in izkopal neznani nepooblaščen iskalec starin. Datum odkritja, natančna lega in okoliščine najdbe niso več znani.\*

\* Članek je nekoliko predelano in dopolnjeno poglavje moje doktorske disertacije (Veronika Pflaum, *Poznorimski obrambni in vojaški sledovi 5. stoletja na ozemlju sedanje Slovenije*, Odde-

Del najdb je, po sicer nezanesljivih podatkih hranitelja zbirke Janeza J. Švajncerja, skoraj gotovo sestavljal zakladno najdbo kovinskih predmetov iz poznorimskega časa. Kateri predmeti so zakladno najdbo sestavljali, ni več točno znano, zato je skupina najdb, ki jih hrani Vojni muzej, predstavljena v celoti. Poskus rekonstrukcije sestava zakladne najdbe temelji na skromnih ustnih podatkih o njej, na dataciji posameznih predmetov, ki bi v nekaterih primerih lahko upravičila izločitev

lek za arheologijo, Filozofska fakulteta Univerze v Ljubljani, Ljubljana [2004]).

iz domnevnega sestava zakladne najdbe z Vodice, in na primerjavi s sestavi sočasnih sorodnih zakladnih najdb z ozemlja Slovenije, ki bi nekatere predmete z določeno verjetnostjo lahko vključila oziroma izključila iz sestava zakladne najdbe.

### ARHEOLOŠKO NAJDIŠČE VODICE PRI KALCAH

Arheološko najdišče Vodice pri Kalcah leži ob trasi rimske ceste med Logatcem (*Longaticum*) in Hrušico (*Ad Pirum*), na ravnini pred vzponom na Lanišče (*sl. 1; 2*). V osemdesetih letih prejšnjega stoletja so bili na najdišču ob polaganju plinovoda pobrani številni raznovrstni rimski predmeti<sup>1</sup> in novci iz 1. do 4. st. po Kr. (najmlajši določljivi novci so iz kovnega obdobja 378-383).<sup>2</sup> Pozneje so najdišče ropali nepooblaščenim iskalci starin ob pomoči detektorjev kovin. Najdbe najverjetneje pripadajo neki rimski obcestni postojanki ali vasi (*vicus*) z lesenimi stavbami, saj zidane gradbene ostaline niso bile odkrite.<sup>3</sup>

Nekoliko jugozahodno od najdišča predmetov na Vodice je bil očiščen in dokumentiran 20 m dolg odsek rimskega cestišča na začetku vzpona z Vodice na Lanišče. Cesta je bila kot terasa zasekana v pobočje, v živo skalo cestišča sta bili izdolbeni koleznici. Najdba srebrnika cesarja Leopolda I. iz leta 1680 dokazuje, da je bil odsek rimske ceste, ki je vodil čez Vodice in Lanišče, v uporabi še konec 17. st.<sup>4</sup> Leta 1686 je bil ob obnovi ceste odkrit rimski miljniki, vendar sta kot najdišče navedeni ali Hrušica ali Vodice.<sup>5</sup>

### KATALOG

Vse predmete hrani J. J. Švajncer v svojem Vojnem muzeju v Logatcu. Ker nimajo inventarnih števil ali drugih oznak, so bili v Narodnem muzeju Slovenije z zaporednimi številkami zapisani v seznam najdb v zasebni lasti. Predmeti niso objavljeni, razen meča z deloma nožnice.

V katalogu so predmeti razvrščeni po skupinah glede na namembnost, ne glede na časovno pripadnost: orožje (meč, dela nožnice, sulične osti, plumbati), orodje ali kuhinjski pripomočki (noži), merilna priprava (tehtnica), orodje (bradve, sekiri, tesla, kopača, kladivo, nož za les, sveder, šestilo, nakovalo), konjska oprema in deli vozov (obuvala kopit, podkvi, sornik), drugo (šilo, konicast predmet). Kataloški opis posameznega predmeta vsebuje oznako predmeta, podroben opis, podatke o merah in teži ter zaporedno številko s seznama najdb v zasebni lasti (št. ZN), ki ga vodi Narodni muzej Slovenije.

Predmeti rekonstruirane domnevne zakladne najdbe so predstavljeni na tablah 1-4 na koncu besedila, ostali na slikah med besedilom. Med besedilom sta tudi fotografiji tehtnice in nakovala iz zakladne najdbe. Številke predmetov na tablah in slikah se ujema s številkami teh predmetov v katalogu.

1. Železen dvorezni meč (*sl. 3: 1*). Delno ohranjen trn je ploščat in pravokotnega preseka, prehod v rezilo je poševno

<sup>1</sup> Frelih 1985; Frelih 1988, 36-40; Švajncer 2003; Pröttel 1996, 211, Taf. 21: 4,6,7 (trije odlomki krožnikov afriške sigilate oblik Hayes 50A [dat. 230-340], Hayes 59 [dat. 340-420] in Hayes 61A [dat. 350-410/420]).

<sup>2</sup> Kos, Šemrov 1995, 227-237, št. 95; Šemrov 1998, 213-219, št. 99.

<sup>3</sup> Frelih 1988, 36. Najdbe, pobrane ob polaganju plinovoda, hrani Inštitut za arheologijo ZRC SAZU v Ljubljani in niso objavljene. Za osnovno informacijo o njih in podatek o domnevni naselbini lesenih stavb se zahvaljujem dr. Slavku Ciglenceškemu z omenjenega inštituta.

<sup>4</sup> Frelih 1988, 36-39.

<sup>5</sup> *CIL* III 4614 = 15198; Sticotti 1951, 123 št. 377; Petru 1975, 123.

stopničast. Rezilo lečastega preseka se rahlo oži proti razmeroma topi, zaobljeni konici.

Ohr. dol. 59,2 cm, dol. rezila 56,6 cm, šir. rezila do 4,0 cm, deb. rezila do 0,7 cm, deb. trna 0,5 cm, ohr. dol. trna 2,6 cm, šir. trna do 1,7 cm, teža 528 g; ZN št. 130/2.

Objava: Švajncer 2003.

2. Železen zaključek nožnice (*sl. 3: 2; 4; 5*). Zaključek nizke cilindrične oblike s pravokotno odprtino v plašču je okrašen s tavširanim okrasom. Motivi okrasa so razpoznavni po vrezih, v katere je bila prej vložena medeninasta žička, sedaj ohranjena le na redkih mestih. Sprednja stran je s križajočima se pasovoma razdeljena v štiri polja, obdana s koncentričnimi krogi. V pasovih je motiv tekoče spirale, v poljih so srčasto razporejeni motivi lista, v vsakem listnem polju je motiv vitice z listom v obliki triperesne deteljice. Na zadnji strani so motivi lista križno razporejeni v štiri listno rozeto, obdana s koncentričnimi krogi na robu. V vmesnih poljih so vitice. Plašč je okrašen s tremi vzdolžnimi črtami. Okrogli ploskvi sta rahlo izbočeni, stik sprednje ploskve in plašča je poškodovan oziroma delno razprt. Na stiku okrašenih ploskev s plaščem je ponekod vidna tanka linija spajke. Notranjost predmeta je zapolnjena z neznan organsko? snovjo, sredina okova je predrta z luknjico.

Pr. 6,5 cm, deb. 1,6 cm, velikost odprtine 4,1 × 1,0 cm, teža 86 g; ZN št. 91/4.

Objava: Švajncer 2003.

3. Železna zanka za obešanje meča na jermen. Predmet ni bil dostopen za ogled, podrobnejši opis in risanje, ker ga hranitelj ni našel. ZN št. 130/2.

Objava: Švajncer 2003.

4. Železna sulična ost (*sl. 8: 4*). Kratek tul se nadaljuje v list rombičnega preseka in ustvarja rebro, na tulu sta dve luknjici, list je najširši ob tulu.

Dol. 17,1 cm, šir. lista 4,2 cm, pr. tula 2,35 cm, teža 186 g; ZN št. 130/16.

5. Železna sulična ost (*sl. 8: 5*). List je ozek, tul se nadaljuje v list in ustvarja rebro, konica lista je rombičnega preseka. Na koncu dolgega tula sta luknjici, v eni je žebelj.

Dol. 21,8 cm, šir. lista 2,55 cm, pr. tula 2,1 cm, deb. lista 1,1 cm, teža 154 g; ZN št. 130/17.

6. Železna ost (*sl. 8: 6*). Dolga konica kvadratnega preseka prek rahle zožitve prehaja v nesklenjen tul okroglega preseka z luknjico. Tul je poškodovan.

Ohr. dol. 20,4 cm, pr. tula 1,5 cm, teža 56 g; ZN št. 130/18.

7. Železna *plumbata* (*sl. 9: 7*). Sestavljena je iz kratke železne osti s konico kvadratnega preseka z rahlo izvihanima zalustma in ovalnega svinčenega obežila na koncu tula. Notranjost tula je zapolnjena z ostanki lesenega držaja.

Dol. 10,5 cm, pr. svinčenega obežila 1,6 cm, šir. konice 1,4 cm, teža 20 g; ZN št. 130/19.

8. Železna *plumbata* (*sl. 9: 8*). Sestavljena je iz kratke železne osti s konico večkotnega preseka z zalustma in svinčenega obežila na koncu tula. Nesklenjen tul je okroglega preseka, v luknjici je žebliček. Svinčeno obežilo je ohranjeno le v sledeh.

Dol. 11,6 cm, pr. tula 1,2 cm, šir. konice 1,5 cm, teža 16 g; ZN št. 130/20.

9. Železen nož (*sl. 10: 9*). Rezilo z debelim, zalomljenim hrbtom od trna ločuje ovalen branik, širok kot rezilo. Ploščat trn pravokotnega preseka je zaključen z bakrenim? ploščatim gumbom, ki je poškodovan.

Dol. 32,4 cm, šir. 4,2 cm, dol. trna 10,8 cm, deb. hrbta rezila 1,1 cm, teža 306 g; ZN št. 130/21.

10. Železen nož (*sl. 10: 10*). Ozko rezilo z ravnim hrbtom poševno preide v ozek dolg trn kvadratnega preseka s pravokotnim, rahlo izbočenim gumbom na koncu. Konica noža je poškodovana.

Ohr. dol. 18 cm, šir. 2,3 cm, teža 28 g; ZN št. 130/22.

11. Železen nož (*sl. 10: 11*). Široko rezilo z ravnim hrbtom poševno preide v trn pravokotnega preseka. Konec trna manjka.



Ohr. dol. 16 cm, šir. 3,4 cm, deb. 0,5 cm, teža 54 g; ZN št. 130/26.

12. Železen nož (*sl. 10: 12*). Rezilo z ravnim hrbtom na strani hrbta stopničasto preide v širok kratek trn pravokotnega preseka. Konica rezila je poškodovana.

Ohr. dol. 18,1 cm, šir. 3,1 cm, deb. 0,7 cm, teža 60 g; ZN št. 130/27.

13. Železen nož (*sl. 10: 13*). Rezilo listaste oblike usločeno prehaja v ploščat ročaj pravokotnega preseka, ki je na koncu razširjen.

Dol. 19,6 cm, šir. 3,2 cm, deb. 0,7 cm, teža 110 g; ZN št. 130/23.

14. Železen nož (*sl. 10: 14*). Rezilo listaste oblike usločeno prehaja v ploščat ročaj pravokotnega preseka, ki je na koncu razširjen.

Dol. 17 cm, šir. 2,8 cm, deb. 0,6 cm, teža 74 g; ZN št. 130/24.

15. Bronasta in železna hitra tehtnica s svinčeno utežjo (*t. I: 15; sl. II*). Bronasta prečka z daljšo ročico skale rombičnega preseka in krajšo ročico bremena kvadratnega preseka se na obeh koncih končuje s stožčastim gumbom. Desni gumb je od ročice bremena ločen z globokim krožnim utorom. Na ročici bremena so tri okrogla ušesca, pritrjena skozi prečko. Levo (deformirano) in desno ušesce sta bronasti, sklenjeni in zakovičeni skozi prečko, srednje je železno, narejeno iz ukrivljene žice in pritrjeno skozi prečko kot razcepka. V ušescih so trije različni kavljji za obešanje tehtnice: levi bronasti kavelj je upognjen iz tanke ploščate žice z odebeljeno konico, spodnji konec je zapognjen nazaj; desni bronasti kavelj je upognjen iz žice kvadratnega preseka z rahlo odebeljeno konico, spodnji konec je zavrt v obliko črke S; srednji, železni kavelj je upognjen iz debelejšje ploščate žice s stanjšano, ostro konico, spodnji konec je spiralno ovit okrog spodnjega dela kavljja. V utoru med ročico bremena in končnim gumbom je obešen verižni obešalnik za breme, sestavljen iz železnega, s strani sploščenega člena v obliki grške črke omega, železnega člena v obliki črke U in dveh verig. Verigi sestavljajo po trije členi iz tordirane železne žice in po en končni člen iz tanjše bronaste žice, katere konca sta zavita nazaj in se ovijata okrog sredine člena. Na prvi verigi je ohranjen s strani sploščen železen kavelj za breme, kavelj na drugi verigi manjka. Prva skala, za tehtanje lažjih bremen, je vidna še v celoti in je z oznakami v obliki navpičnih črt (za 1-4, 6-9, 11, 12) in črk V in X (za 5 in 10) razdeljena na 12 enot. Druga skala skoraj ni več vidna, začne se z oznako dveh X (na mestu za vrednost 10; naknadno popravi oznake?), vidna je tudi prva oznaka V (za 15), sledi sledečih oznak so komaj vidne. Tretja skala, za tehtanje najtežjih bremen, je vidna le deloma, začne se z oznako XXX (za 30), sicer se menjavata oznaki V in X za petice in desetice. Na ročico skale je z železnim kavljem, sploščenim s strani, obešena svinčena utež kroglaste oblike.

Dol. prečke 29,6 cm, dol. ročice skale brez gumba 19,4 cm, deb. ročice skale 0,8 cm, dol. ročice bremena brez gumba 8,2 cm, deb. ročice bremena 1,0 cm, razdalja med začetkom ročice bremena in sredino levega ušesca 0,8 cm, razdalja med sredino levega in srednjega ušesca 4,4 cm, razdalja med sredino srednjega in desnega ušesca 1,9 cm, razdalja med sredino desnega ušesca in utorom 1,1 cm, razdalja med prvo oznako prve skale in sredino levega ušesca 2,4 cm, razdalja med prvo oznako druge skale in sredino srednjega ušesca 5,7 cm, razdalja med prvo oznako tretje skale in sredino desnega ušesca 7,7 cm, razdalja med prvo in zadnjo oznako prve skale 16,7 cm, razdalja med prvo in zadnjo oznako tretje skale 19,3 cm, dolžina prve skale 18,2 cm, dolžina tretje skale 19,3 cm, dol. verižnega obešalnika 44 cm, pr. svinčene uteži 6,6 cm, dol. uteži s kavljem 15,7 cm, teža uteži s kavljem 1486 g, teža tehtnice brez uteži 296 g, skupna teža 1782 g. Verižni obešalnik ni bil stehtan, ker ga ni mogoče sneti s prečke in ker ni v celoti ohranjen. ZN št. 91/1.

16. Železna bradva (*t. 2: 16*). Uho z ovalno luknjo je na obeh straneh ojačano z nizkimi pravokotnimi krilci. V luknji je ohranjen les toporišča.

Viš. 14 cm, šir. 9,5 cm, deb. 3,55 cm, teža 594 g; ZN št. 130/34.

17. Železna bradva (*t. 2: 17*). Čelo je rahlo povišano, uho z ovalno luknjo je na obeh straneh ojačano z nizkimi pravokotnimi krilci.

Viš. 18,4 cm, šir. 16,4 cm, deb. 3,9 cm, teža 1094 g; ZN št. 130/35.

18. Železna bradva (*t. 2: 18*). Nizko uho ima luknjo zaobljene pravokotne oblike.

Viš. 14,4 cm, šir. 14,2 cm, deb. 3,4 cm, teža 556 g; ZN št. 130/33.

19. Železna sekira (*t. 2: 19*). Podaljšano čelo se zaključuje s štirimi zobci. List se simetrično širi proti ostrini, v ovalni luknji ušesa so sledi lesenega toporišča.

Viš. 13,6 cm, dol. čela 10,8 cm, deb. 2,0 cm, teža 390 g; ZN št. 130/31.

20. Železna sekira (*t. 2: 20*). Čelo je podaljšano, ozek list je nesimetrično razširjen navzdol. V ovalni luknji ušesa so ostanki lesenega toporišča.

Viš. 21 cm, dol. čela 11,2 cm, deb. 3,8 cm, teža 1214 g; ZN št. 130/32.

21. Železno teslo (*t. 3: 21*). Čelo je kratke kladivaste oblike, list je upognjen, uho z luknjo ovalne oblike je na obeh straneh ojačano z neizrazitimi zaobljenimi krilci.

Viš. 16,5 cm, šir. lista 6 cm, vel. čela 3,5 × 3,6 cm, teža 556 g; ZN št. 130/29.

22. Železno teslo (*t. 3: 22*). Čelo je kratke kladivaste oblike, list je upognjen, uho z luknjo ovalne oblike je na obeh straneh ojačano z nizkimi zaobljenimi krilci.

Viš. 21,3 cm, šir. lista 7,8 cm, vel. čela 3,2 × 4,1 cm, teža 914 g; ZN št. 130/28.

23. Železno dvostrano teslo (*t. 3: 23*). Prvi list je oblikovan kot teslo, konec drugega lista ima navzdol zaobljeno zavihane robove v plitvo žlebasto obliko.

Viš. 23,7 cm, šir. 5,3 cm, teža 404 g; ZN št. 130/30.

24. Železna kopača (*t. 3: 24*). En konec je v obliki črke V razcepljen v ravna roglja kvadratnega preseka, list na drugem koncu je široke trikotne oblike. Uho z luknjo ovalne oblike je na obeh straneh ojačano z zaobljenimi krilci.

Viš. 23,8 cm, šir. 12,2 cm, teža 660 g; ZN št. 130/25.

25. Železno kladivo (*sl. 12: 25*). Čelo kladiva je okroglo, kraka kljuna sta razcepljena v obliki črke V. Prvi krak se konča ravno, drugi v obliki trikotne konice. Uho z luknjo zaobljene pravokotne oblike je ojačano s krilcema, v luknji ušesa je ostanek traku z razširjeno glavo.

Viš. 14 cm, šir. 4,1 cm, deb. 3,0 cm, pr. čela 2,3 cm, teža 186 g; ZN št. 130/12.

26. Ploščat železen žebelj (*sl. 12: 26*) pravokotnega preseka z ozko pravokotno glavico, odlomljen.

Dol. 7,45 cm; ZN št. 130/12.

27. Železen žebelj (*sl. 12: 27*) kvadratnega preseka s pravokotno glavico, zvit in odlomljen.

Dol. 3,15 cm; teža žebeljev skupaj 8 g; ZN št. 130/12.

28. Železen rezilo za izdelavo lesenih predmetov (*t. 3: 28*). Rezilo je ob trnu pravokotnega preseka, postavljenem pravokotno na rezilo, ukrivljeno. Na nasprotni strani prehaja v ploščat podaljšek, ki se zaključuje z zanko.

Ohr. dol. 46 cm, šir. rezila 4,5 cm, deb. 1,3 cm, teža 726 g; ZN št. 130/15.

29. Železen žličast sveder (*t. 4: 29*). Steblo je okroglega preseka, ploščato in ozko koničasto nasadilo za ročaj listaste oblike pa pravokotnega preseka.

Dol. 31,4 cm, šir. žličke 2,2 cm, šir. nasadila 2 cm, pr. stebila 1,1 cm, teža 164 g; ZN št. 130/11.

30. Železno šestilo (*t. 4: 30*). Kraka pravokotnega preseka sta na vrhu skovana v ploščati polkrožni ploščici. Spojeni sta z

osjo, ki je na eni strani sploščena, na drugi pa skovana v nizko izbočeno glavico.

Dol. 36,4 cm, šir. ploščic 3,6 cm, deb. 2,1 cm, teža 438 g, ZN št. 130/10.

31. Železno nakovalo (*t. 4: 31; sl. 13*). Nakovalo kockaste oblike ima rahlo izbočeno zgornjo, udarno ploskev z izvihanimi robovi. Spodnja, stojna ploskev je rahlo vbočena, njeni robovi so močno vbočeni in poševno posneti, s čimer so v spodnjih vogalih nakovala oblikovane majhne, nizke koničaste nogice trikotnega preseka.

Vel. udarne ploskve 21 × 22 cm, viš. 20 cm, teža 50 kg; ZN št. 130/1.

32. Železno obuvalo kopita (*sl. 14: 32*). Dolg navpičen prednji del ploščatega pravokotnega preseka se konča z ožjim zunanji zavojem kvadratnega preseka. Stranski krilci sta izbočeni, v podplatu so štiri piramidaste konice, obuvalo se zadaj konča s privzdignjenim kavljem pravokotnega preseka.

Dol. 20 cm, šir. 12 cm, viš. 12 cm, teža 570 g; ZN št. 130/4.

33. Železno obuvalo kopita (*sl. 14: 33*). Dolg navpičen prednji del ploščatega pravokotnega preseka se konča z ožjim zunanji zavojem kvadratnega preseka. Stranski krilci sta izbočeni, v podplatu so štiri piramidaste konice, obuvalo se zadaj konča z rahlo privzdignjenim kavljem kvadratnega preseka. Krilci in zadnji del podplata so poškodovani.

Dol. 19 cm, šir. 13,2 cm, viš. 10 cm, teža 628 g; ZN št. 130/6.

34. Železno obuvalo kopita (*sl. 15: 34*). Dolg navpičen prednji del ploščatega pravokotnega preseka se je končal z ožjim zunanji zavojem, ki manjka. Stranski krilci sta izbočeni, v podplatu so štiri piramidaste konice, obuvalo se zadaj konča s privzdignjenim kavljem kvadratnega preseka. Na spodnji strani podplata so spredaj trije vzporedni vzdolžni žlebovi, ki segajo skoraj do sredine podplata, ob konicah pod stranskima krilcema pa po dva kratka vzporedna prečna žleba. Krilci in zadnji del podplata so poškodovani.

Dol. 17,4 cm, šir. 10,7 cm, viš. 12,3 cm, teža 490 g; ZN št. 130/5.

35. Železno obuvalo kopita (*sl. 15: 35*). Dolg navpičen prednji del ploščatega pravokotnega preseka se konča z ožjim zunanji zavojem kvadratnega preseka. Stranski krilci sta izbočeni, v podplatu so štiri piramidaste konice, obuvalo se zadaj konča z rahlo privzdignjenim kavljem kvadratnega preseka. Krilci sta poškodovani.

Dol. 21,7 cm, šir. 14,45 cm, viš. 9,75 cm, teža 480 g; ZN št. 130/7.

36. Železno obuvalo kopita (*sl. 15: 36*). Dolg navpičen prednji del ploščatega pravokotnega preseka se konča z velikim zunanji zavojem ožjega pravokotnega preseka. Stranski krilci sta izbočeni, v podplatu so tri piramidaste konice. Zadnji del podplata s četrto konico in kavljem manjka.

Ohr. dol. 14,7 cm, šir. 13,3 cm, viš. 10,35 cm, teža 652 g; ZN št. 130/3.

37. Železna podkev (*sl. 16: 37*). Podkev je tanka in široka, zunanji rob je rahlo privzdignjen, kraka se enakomerno ožita proti koncu. Na robu krakov je plitev žleb, v katerem so po štiri pravokotne luknje za žeblje. V dveh luknjah sta ohranjena žeblja s trnom pravokotnega preseka in podolgovato pravokotno izbočeno glavico. Konca krakov sta poškodovana.

Ohr. dol. 11,5 cm, šir. 10,8 cm, deb. 0,6 cm, teža 116 g; ZN št. 130/8.

38. Železna podkev (*sl. 16: 38*). Podkev je tanka in široka, zunanji rob je rahlo odebeljen z rebrom, kraka se enakomerno ožita proti koncu. Na robu krakov je plitev žleb, v katerem so po štiri pravokotne luknje za žeblje. V eni luknji je ohranjen žebelj s trnom pravokotnega preseka in podolgovato pravokotno izbočeno glavico. Del enega kraka manjka.

Dol. 10,5 cm, šir. 10,2 cm, deb. 0,65 cm, teža 96 g; ZN št. 130/9.

39. Železen sornik (*t. 4: 39*). Dolgo steblo je cilindrične oblike, vrh je skovan v ploščato pravokotno glavo, ki je poškodovana. Konec stebela je votel, v steni je luknja nepravilne pravokotne oblike.

Dol. 62,3 cm, pr. 2,8 cm, vel. glave 3,7 × 8,3 cm, teža 2462 g; ZN št. 130/37.

40. Železno šilo (*t. 4: 40*). Šilo kvadratnega preseka se navzdol oži in konča s konico, sploščen vrh pravokotnega preseka je oblikovan v nesklenjen zavoj.

Dol. 16 cm, šir. 1,4 cm, teža 24 g; ZN št. 130/13.

41. Železen predmet (*sl. 18*). Predmet koničaste oblike pravokotnega preseka s fasetiranimi robovi se enakomerno oži proti vrhu okroglega preseka, ki je ukrivljen. Spodaj se poševno zoži v kratek trn nepravilnega kvadratnega preseka.

Dol. (ukrivljeno) 9,9 cm, šir. 1,1 cm, teža 24 g; ZN št. 130/14.

#### Gradivo rekonstruirane domnevne zakladne najdbe

Tabla 1: kat. št. 15.

Tabla 2: kat. št. 16-20.

Tabla 3: kat. št. 21-24, 28.

Tabla 4: kat. št. 29-31, 39, 40.

#### OPREDELITEV NAJDB

##### Orožje

##### *Meč in dela nožnice*

Železen dvorezni meč z Vodic (*sl. 3: 1*) sodi med rimskodobne dolge meče (*spathae*), ki so sicer pogosto deležni pregledne obravnave,<sup>6</sup> vendar se z nobenim izmed določenih tipov ali posameznih primerkov ne ujema v vseh oblikovnih podrobnostih in merah, primerjanje otežuje tudi nepopolna ohranjenost. Zato si lahko pomagamo le s splošnimi ugotovitvami o oblikovnem in kronološkem razvoju tovrstnih mečev, ki temeljijo predvsem na raziskavah rimskih mečev v barbariku, saj so najdbe mečev na rimskem ozemlju redke.

Günter Ulbert je rimske dolge meče 3. st. na podlagi mer ter razmerja med dolžino in širino rezila razdelil v dva sočasna tipa (kratek širok in ozek dolg tip): tip Lauriacum-Hromówka (šir. rezila 6,2-7,5 cm, razmerje dol. : šir. = 8-12 : 1) in tip Straubing-Nydam (šir. rezila največ 4,6 cm, razmerje dol. : šir. = 15-17 : 1).<sup>7</sup> Meč z Vodic se ne ujema povsem s katerim od tipov, saj bi se po širini rezila (4,0 cm) uvrščal v tip Straubing-Nydam, zaradi kratkosti rezila (56,6 cm) pa je razmerje med dolžino in širino rezila (14,15 : 1) nekje vmes med obema tipoma, vendar bližje že omenjenemu tipu.

Meče 3. st. in pozne rimske dobe, ki po merah, ne pa nujno oblikovnih podrobnostih, ustrezajo meču z Vodic, je Piotr Kaczanowski imenoval tip Augst.<sup>8</sup> Njihova rezila so dolga od 55 do 60 cm, široka pa okoli 4 cm, kar se povsem ujema z merami meča z Vodic. Omenja le štiri primerke, izmed katerih je meč iz Augsta datiran v 3. st.

Rimski dolgi dvorezni meči ali *spathae* se pojavljajo predvsem od 3. st. dalje. Le na podlagi dolžine ni mogoče razpoznati kronološkega razvoja mečev in torej ne datirati posamezne najdbe meča. Dolžina (in širina) rezil sicer sčasoma narašča, vendar

<sup>6</sup> Ulbert 1974; Schulze-Dörrlamm 1985; Lønstrup 1986; Kaczanowski 1992; Biborski 1994; Rald 1994; Ilkjær 1994; tudi Bishop, Coulston 1993, 69-74, 126, 162; Feugère 1993, 147-150, 246; Menghin 1983, 15-16.

<sup>7</sup> Ulbert 1974, 199-204.

<sup>8</sup> Kaczanowski 1992, 30, rys. 3: 1-4.

še le od 4. st. dalje.<sup>9</sup> Neko povezavo med dolžino rezil in datacijo je na danskem močvirskem najdišču Illerup Ådal opazil Jørgen Ilkjær. Meči z mesta, kjer sta se prekrivala depozita predmetov A in B, datirana v čas okoli leta 200 (A) in po letu 200 (B), so imeli rezila, dolga od 61,5 do 78,0 cm. Meči z depozitnega mesta C, datiranega v čas okoli leta 400 ali malo prej, pa so imeli rezila, dolga od 76,5 do 85,5 cm. Jasne razlike med meči prve (A, B) in druge (C) skupine, ki sta ostro časovno ločeni, je opazil tudi v dolžini ročajnega trna in obliki prereza rezila, vendar ugotovitve za meč z Vodice niso pomembne, saj nima ročajnega trna, med danskimi meči pa ni nobenega z lečastim prerezom.<sup>10</sup> Rezilo meča z Vodice je krajše od mečev obeh skupin, vendar blizu prvi, datirani v začetek ali prvo četrtino 3. st. po Kr. Pri istih mečih je že Jørn Lønstrup opazil, da ostrini rezil mečev starejše skupine izraziteje konvergirata, pri mečih mlajše skupine pa sta skoraj vzporedni.<sup>11</sup> Rezilo meča z Vodice se s 4 cm v bližini ročajnega trna zoži na 3 cm pred konico, kar bi verjetno ustrezalo mečem starejše skupine z danskega najdišča. Ali je mogoče ugotovitve o mečih z najdišča Illerup Ådal prenesti splošno na rimske meče, še ni bilo preverjeno.

Mechthild Schulze-Dörrlamm je opazovala širino rezil mečev v dobro datiranih germanskih grobovih poznega 3. in 4. st.<sup>12</sup> Ugotovila je, da so meči z zelo ozkim rezilom (3,0 do 4,4 cm) starejši od mečev s širino rezila, večjo od 4,5 cm. Obravnavani meči z zelo ozkimi rezili so bili v uporabi v poznem 3. st. in še v prvi polovici 4. st., v drugi polovici pa so že izginili. Meč z Vodice ustreza njeni skupini mečev z zelo ozkim rezilom, saj je njegovo rezilo široko 4 cm.

Iskanje konkretnih primerjav oziroma podobnih mečev kot pomoč pri opredelitvi meča z Vodice je vprašljivo, saj se noben meč ne ujema z njim v prav vseh podrobnostih, ni pa znano, katera izmed oblikovnih in merskih podrobnosti je res pomembna oziroma pomembnejša od drugih za časovno in siceršnje opredelitev. Kljub temu lahko naštejemo nekaj primerjav, večinoma z rimskega ozemlja.

Meč skoraj povsem enake oblike, le daljši in z bolj pravokotnim prehodom rezila v ročajni trn, je bil neznano kdaj, v neznanih najdiščnih okoliščinah izkopen v Carnuntu.<sup>13</sup> Je eden redkih mečev, ki ima, tako kot meč z Vodice, lečast presek rezila. Lečast presek rezila ima tudi soroden meč manjših mer iz groba z najdišča Alzey, datiranega v pozno 3. in zgodnje 4. st.<sup>14</sup>

Meču z Vodice po merah in obliki (oblika konice, prehoda rezila v ročajni trn, preseka) podoben meč je bil najden tudi v Belgiji, na najdišču Liberchies. Datiran je v prvo četrtino 3. st., od meča z Vodice pa se razlikuje po izrazitejšem oženju rezila proti konici in nekoliko večji dolžini rezila.<sup>15</sup>

Štirje sorodni meči, datirani v 3. st. in uvrščeni v tip mečev Straubing-Nydam G. Ulberta, so bili izkopani v Avgustu.<sup>16</sup> Od meča z Vodice se razlikujejo predvsem po fasetiranem preseku rezila in pravokotnejšem prehodu rezila v ročajni trn.

Na podlagi splošnih ugotovitev o rimskodobnih dolgih dvoreznih mečih in na podlagi konkretnih primerjav lahko meč z Vodice datiramo v 3. st. Po dveh različnih tipoloških delitvah bi ga lahko uvrstili pogojno v tip Straubing-Nydam G. Ulberta oziroma v tip August P. Kaczanowskega, oba značilna tipa mečev 3. st.

Ob meču sta bila v prvotni legi najdena tudi dela nožnice - železna zanka za obešanje na jermen (*kat. št. 3*) in železen zaključek nožnice v obliki ploske okrogle škatlice s tavširanim okrasom

<sup>9</sup> Feugère 1993, 147-148; Menghin 1983, 16.

<sup>10</sup> Ilkjær 1994, 236, 239.

<sup>11</sup> Lønstrup 1986, 748.

<sup>12</sup> Schulze-Dörrlamm 1985, 542 op. 31, Tab. 1. O širini rezil mečev in razmerjih med širino in dolžino rezil tudi Künzl 1993.

<sup>13</sup> Ponstingl 1986, 273, Abb. 32.

<sup>14</sup> Schulze-Dörrlamm 1985, 511 št. 2, 542, Abb. 3: 1.

<sup>15</sup> Berghe 1996, 80, fig. 12: 3.

(*sl. 3: 2; 4; 5*). Tovrstni zaključki so krasili nožnice dolgih ozkih mečev predvsem 3. st. Poleg železnih s tavširanim okrasom, ki so najpogostejši, so znani tudi srebrni z niello okrasom, bronasti in slonokoščeni zaključki.<sup>17</sup> Meči z okroglimi zaključki nožnice so kot del vojaške oprave nekajkrat upodobljeni tudi na kamnitih nagrobnih spomenikih.<sup>18</sup> V Sloveniji je tak vojaški nagrobnik vzidan v južno zunanjo steno cerkvice sv. Miklavža v Vrbi nad Dobrno pri Celju (*sl. 6*).<sup>19</sup> Nagrobnik je bil odkrit leta 1890 v tlaku cerkvice. Na njem je nad napisnim poljem celopostavna upodobitev pokojnika Avrelija Viktorja v popolni vojaški opravi z ovalnim ščitom, sulico, dolgim mečem z velikim okroglim zaključkom nožnice, širokim pasom, kratko tuniko in plaščem, spetim na desnem ramenu. Služil je v 2. italjski legiji in bil v starosti 30 let pogrešan v vojni z Goti. Nagrobnik je bil na podlagi načina zapisa besedila in noše datiran v sredino ali drugo polovico 3. st.<sup>20</sup>

Arheološke najdbe okroglih zaključkov nožnic mečev so bile že večkrat predmet izčrpnih in preglednih znanstvenih obravnav,<sup>21</sup> zato sledi le povzetek nekaterih ugotovitev, pomembnih za najdbo z Vodice. Železni zaključki nožnic s tavširanim okrasom se pojavljajo ob germanskem limesu in v barbariku,<sup>22</sup> najdbe drugod (kot na primer na Vodiceh) so zaenkrat izjeme.<sup>23</sup> Glede na način razporeditve okrasnih motivov sta bili opisani dve skupini. V prvi skupini so motivi razporejeni osno simetrično ob vzdolžnih oseh, križno ali v izsekih po četrt kroga. Glavni motivi so preproste vitice z listi, tekoča spirala in občasno na sredini rozeta. Premer zaključkov prve skupine je nekje med 6,4 in 7,2 cm. V drugi skupini so motivi razporejeni v več koncentričnih kolobarjih in vsaj deloma zasnovani s šestilom. Zaključki s tako razporeditvijo motivov so večji, njihov premer je med 8,5 in 9,6 cm. Skupini se razlikujeta tudi v obliki zaključkov: manjši zaključki, z okrasom prve skupine, imajo ploski ali rahlo izbočeni okrogli ploskvi; večji zaključki, z okrasom druge skupine, imajo praviloma plosko zadnjo stran in izbočeno prednjo stran s stožčasto izboklino ali konkavno vdolbino na sredini. Dokončne datacije obeh skupin še ni. Zaključki druge skupine domnevno sodijo v drugo polovico 3. st., vendar se tudi zaključki prve skupine pojavljajo še po sredini 3. st.<sup>24</sup> Zaključek nožnice z Vodice s svojimi motivi, njihovo razporeditvijo, premerom 6,5 cm in rahlo izbočenima okroglima ploskvama popolnoma ustreza prvi skupini.

Kljub enakemu izboru motivov in skupnim potezom v zasnovi okrasa je vsak zaključek unikat, okrašen nekoliko drugače. Primerjave okrasu na zaključku z Vodice zato najdemo za posamezna okrasna polja, ne pa za okras sprednje ali zadnje strani v celoti. Srčasta polja z motivom vitice in lista v obliki triperesne deteljice, kakršna so na sprednji strani zaključka z Vodice, so tudi na zaključku iz kastela Zugmantel (*sl. 7: a*),<sup>25</sup> vendar so tam vitice predstavljene podrobneje, bolj razvejeno. Tudi okras

<sup>16</sup> Martin-Kilcher 1985, 174 št. 2, Abb. 21: 1, 183 št. 19, 20, Abb. 25: 2,3, 190 št. 45, Abb. 25: 4.

<sup>17</sup> *Ib.*, 158-159.

<sup>18</sup> *Ib.*, 158 op. 19, Abb. 7.

<sup>19</sup> *CIL* III 11700; Saria 1924, 251, 252, Abb. 2; Hoffiller, Saria 1938, 7 št. 10; Petrovitsch 2006, 206-207, z drugo literaturo. Na nagrobnik me je opozoril dr. Dragan Božič, za kar se mu najlepše zahvaljujem.

<sup>20</sup> Hoffiller, Saria 1938, 7 št. 10; Petrovitsch 2006, 206.

<sup>21</sup> Hundt 1953; Hundt 1955; pregledno, s starejšo literaturo Martin-Kilcher 1985, 150-164, Abb. 3-12; Oldenstein 1976, 116, Taf. 22-24; Borhy 1989; Kaczanowski 1992, 47-48, rys. 12; Bishop, Coulston 1993, 130; Lenz-Bernhard 1986.

<sup>22</sup> Martin-Kilcher 1985, 159; Kaczanowski 1992, 47, 91, zast. 9.

<sup>23</sup> Borhy 1989.

<sup>24</sup> Martin-Kilcher 1985, 159.

<sup>25</sup> Hundt 1953, 66, Abb. 1: 2a; 4.

krizajočih se pasov z motivom tekoče spirale s sprednje strani zaključka z Vodice ima edino primerjavo v okrasu na drugi strani istega zaključka iz Zugmantla (sl. 7: b). Okrasni polji nista enaki, saj pasovi z motivom tekoče spirale na zaključku iz Zugmantla obrobajo osrednji motiv krizajočih se linij.<sup>26</sup> Lečasta okrasna polja na robu okroglih ploskev z motivom vitic, kakršna so na zadnji strani zaključka z Vodice, so na zaključkih prve skupine pogosta, vendar motiv vitic običajno dopolnjujejo še listi raznovrstnih oblik, vitice pa so bolj razvejane. Motiv osrednje rozete, vendar nekoliko manjše, je prisoten na zaključku z najdišča Niederbieber.<sup>27</sup> Ob površni primerjavi sloga izdelave okrasa, narejeni na podlagi objavljenih risb, je na zaključku nožnice z Vodice opazna poenostavljena upodobitev motivov v primerjavi z drugimi zaključki prve skupine, znanimi iz literature.<sup>28</sup>

Oblikovna in slogovna opredelitev zaključka nožnice z Vodice, prav tako kot meča, ne omogoča datacije najdbe meča z zanko za obešanje in zaključkom nožnice natančneje kot v 3. st. Le zaključku nožnice z Vodice po okrasu najbližji analogen zaključek iz kastela Zugmantel, ki je bil opuščen leta 260 ob padcu limesa, bi kazal na možnost datacije v prvo polovico ali sredino 3. st.

#### Sulične osti

Sulična ost (sl. 8: 4) med rimskimi predmeti nima primerjave. Njena posebnost je kratek širok tul, ki se zajeda globoko v list, pa tudi reliefno nakazani zalusti na listu, izrazito debela konica lista rombičnega preseka ter oblika lista, ki je najširši nad tulom in ima rahlo usločeni stranici. Enako sulično ost je Viktor Hoffiller sicer umestil na svojo sliko, ki prikazuje rimske sulične osti iz Siska (*Siscia*) ter z drugih najdišč Hrvaške in Slavonije, vendar brez kakršnih koli podatkov o njej, zato datacija v rimsko dobo ne more biti brez dvoma.<sup>29</sup>

Zaradi oblike osti in konice debelega rombičnega preseka, ki spominja na preseke nekaterih mlajših izstrelkov, se zdi, da ni antična, ampak mlajša, to je srednjeveška.

Oblikovne primerjave sulični osti z Vodice (sl. 8: 5) prihajajo z različnih najdišč in iz raznih stoletij.<sup>30</sup> Avtorji, ki so se ukvarjali z rimskimi suličnimi ostmi, opozarjajo na težavnost, neuspešnost poskusov in verjetno nesmiselnost tipoloških klasifikacij suličnih osti, saj zaradi domnevno tako rekoč priložnostnega načina izdelave niti dve osti med seboj nista povsem enaki. Zato suličnih osti samih po sebi na podlagi oblike ni mogoče datirati (nekatero oblike so ostajale nespremenjene tudi vso rimsko cesarsko dobo), datacijo omogočajo le stratigrafski podatki ustrezno izkopanih najdišč.<sup>31</sup> V pomoč je lahko sistematična obravnava suličnih osti z danskega močvirskega najdišča Ille-rup Ådal, ki je bilo tudi ustrezno izkopano in dokumentirano ter v njegovem okviru natančno datirani posamezni depoziti predmetov.<sup>32</sup> J. Ilkjær je kot glavni kriterij za oblikovno delitev

suličnih osti upošteval presek lista, nadalje mere, razmerja med raznimi merami in obris lista. Sulična ost z Vodice ima natančne primerjave v nekaterih primerkih tipa 3 suličnih osti z danskega najdišča, za katere sta značilna rombični presek lista in tul, ki se nadaljuje v list in s tem ustvarja rebro.<sup>33</sup> Depozitno mesto B, v okviru katerega so bile najdene sulične osti tipa 3, je bilo datirano v prvo četrtino 3. st. (pozna perioda C1b). Enake sulične osti z mlajših močvirskih najdišč Danske (Nydam, Ejsbøl) po mnenju J. Ilkjæra kažejo na verjetnost, da sodijo različice suličnih osti tipa 3 v list podaljšanim tulom v pozno cesarsko dobo.<sup>34</sup>

Železna ost (sl. 8: 6) je sestavljena iz dolge ozke konice kvadratnega preseka in nesklenjenega tula. Skoraj povsem enaki osti sta bili najdeni v bližnji utrdbi na Martinj Hribu,<sup>35</sup> ki je glede na novčne najdbe najverjetneje obstajala le krajši čas v drugi polovici 4. st. (približno od šestega desetletja do leta 388).<sup>36</sup>

Primerjavo predstavljata tudi plumbati iz poznorimske utrdbe na Hrušici (*Ad Pirum*), katerih železni osti nimata zalusti, ampak konico kvadratnega preseka.<sup>37</sup> Konica obeh je sicer kratka in se nadaljuje v steblo in tul okroglega preseka, vendar je enako oblikovana kot oglati del osti z Vodice. Utrdba na Hrušici je bila glede na novčne najdbe opuščena v prvih letih 5. st.,<sup>38</sup> *plumbatae* kot vrsta orožja pa so sicer široko datirane v 4. in 5. st.

#### Plumbati

Metalni puščici s svinčnim obtežilom (sl. 9: 7,8) z Vodice dopolnjujeta dosedanja seznam plumbat, posebne vrste poznorimskega orožja, za katero sta značilna železna ost s svinčnim obtežilom na steblo in kratko neohranjeno leseno nasadilo.<sup>39</sup> Orožju so posvečali precejšnjo pozornost že antični pisci,<sup>40</sup> pogoste pa so tudi pregledne obravnave njegovih arheoloških najdb.<sup>41</sup> Primerka z Vodice sodita v najpogostejšo različico, pri kateri ima ost konico z zalustma. Redkeje so različice s konico kvadratnega preseka, s konico lečaste oblike in trikrilno oziroma trirobo konico.<sup>42</sup>

<sup>33</sup> Ib., 43-44, Taf. 7: BQI, BRU; 8: VHR.

<sup>34</sup> Ib., 44, 325.

<sup>35</sup> Leben, Šubic 1990, 327, 318 št. 24, 25, t. 2: 20, 21.

<sup>36</sup> Kos 1986, 203-204.

<sup>37</sup> Giesler 1981, 173, Katalog I/L. 9: 180, Taf. 22: 180; Ciglencečki 1994a, Taf. I: 20.

<sup>38</sup> Kos 1986, 198-199, 201-207.

<sup>39</sup> Opisal jih je anonimni pisec spisa *De Rebus Bellicis* (nastal je v letih 368/9), v štirih srednjeveških prepisih njegovega besedila so tudi narisane, vendar se risbe ne ujemajo z njegovim opisom; Anon. *de rebus bell.* X, XI (Ireland 1979, 10, 30-31, 104, pl. IX). Anonimovi opisi se poleg tega ne ujemajo povsem z arheološkimi najdbami. O videzu tudi Höck 2003, 70, 72, z literaturo.

<sup>40</sup> Anon. *de rebus bell.* X, XI (Ireland 1979, 10, 30-31, 104); Vegetius, *Epitoma Rei Militaris* I 17, II 15, nemški prevod odlomkov pri Degen 1992, 140; o oborožitvi in bojevanju s plumbatami, kot ju opisuje Vegetij, piše Koliaš 1988, 173-174; Bennett 1991, 59.

<sup>41</sup> Prvi jih je zbral in tipološko razdelil Völling 1991, 288-289, 296-298; pregled, dopolnjen seznam in zemljevid najdišč pri Degen 1992; Buora 1997; Höck 2003, 69-73, 161, Fundliste 5; o posameznih najdbah Barker 1979; Marchant 1990, 2; Bennett 1991; Volpert 1997, 266 št. 49, Abb. 11: 10; Radman-Livaja 2004, 31-32, 127 št. 31-35, t. 8: 31, 32; 9: 33-35; o izdelavi Sherlock 1979; o poskusih o načinu uporabe Eagle 1989.

<sup>42</sup> Höck 2003, 70, Abb. 49.

<sup>26</sup> Ib., 66, Abb. 1: 2b.

<sup>27</sup> Ib., 66, Abb. 6: 2a.

<sup>28</sup> Martin-Kilcher 1985, Abb. 8; 9; 27: 5; 28: 1; Oldenstein 1976, Taf. 22: 138, 140; 23; 24: 146.

<sup>29</sup> Hoffiller 1912, sl. 34 na str. 96: druga ost z leve v spodnji vrsti.

<sup>30</sup> Na primer Manning 1985, 166-167, pl. 79: V 106 (najdišče Hod Hill, sredina 1. st. po Kr.); Hübener 1973, 28, Taf. 18: 1-5 (najdišče Augsburg-Oberhausen, niso datirane); Bishop, Coulston 1993, fig. 35: 14 (najdišče Hod Hill, sredina 1. st. po Kr.), fig. 84: 2 (najdišče Caerleon, 3. st.); Marchant 1990, pl. 1: 6 (najdišče Housesteads, Hadrijanova doba ali mlajše).

<sup>31</sup> Marchant 1990; Bishop, Coulston 1993, 69, 123, 126, 162; Feugère 1993, 169-171, 247.

<sup>32</sup> Ilkjær 1990.

Najdbe plumbat (objavljenih je približno 70 primerkov s približno 40 najdišč) so omejene predvsem na prostor severovzhodne Italije in zahodne Slovenije ter Britanije, redko oziroma posamično se pojavljajo tudi ob donavskem in renskem limesu ter v njunem zaledju v Nemčiji, Švici, Avstriji, Italiji, Franciji, na Nizozemskem, Hrvaškem in Madžarskem. Osamljene najdbe prihajajo s spodnjega toka Donave, s Peloponeza in vzhodne obale Črnega morja.<sup>43</sup> Anton Höck podoba razširjenosti razlaga kot posledico stanja raziskav in *plumbatae* pričakuje tudi v notranjosti cesarstva, na primer v Španiji in na Portugalskem ter prek Severne Afrike in Palestine do maloazijskega območja.<sup>44</sup>

*Plumbatae* ali z drugim imenom *mattiobarbuli* naj bi bile po Vegeciju specialno orožje dveh ilirskih legij (*leg. I Iovia, leg. I Herculia*), ki sta do konca (zahodno) rimske oblasti kot elitni enoti delovali na številnih krajih.<sup>45</sup> Ostaja pa nejasno, ali sta bili le ti dve elitni legiji oboroženi s plumbatami ali tudi druge sočasne enote.<sup>46</sup>

*Plumbatae* so poznorimska inovacija, vendar so redko najdene v sklopih, ki bi omogočali natančnejšo datacijo. Najdbe, ki jih je mogoče datirati, kažejo na 4. in 5. st., morda le na začetek petega in že konec tretjega stoletja.<sup>47</sup> Nekoliko večje sorodne metalne puščice so znane še v bizantinski oborožitvi.<sup>48</sup>

Iz Slovenije je, vključno z najdbama z Vodice, znanih 11 plumbat s teh najdišč:<sup>49</sup> Ajdna nad Potoki (1),<sup>50</sup> Hrušica (3),<sup>51</sup> Ljubljana (1),<sup>52</sup> Predjama (1),<sup>53</sup> Podutik (1),<sup>54</sup> Velike Malence

(1),<sup>55</sup> Vodice (2), Ljublanica pri Vrhniku (1).<sup>56</sup> Gre za posamične najdbe ali za najdbe s starih, metodološko neustreznih izkopavanj, zato konteksti najdb, ki bi omogočali natančnejšo datacijo, niso znani. Le primerek z Velikih Malenc je bil najden v zadnjem času, ob izkopavanjih vile rustike pri cerkvi sv. Martina pri Velikih Malencah. Plumbata je bila najdena ob izkopani stavbi na nekakšni tlakovani dvoriščni površini, v kateri so bili novci iz časa od zadnje tretjine 3. do zadnje tretjine 4. st. Rimskodobni stavbni kompleks je bil uničen v požaru okrog leta 378, sledov poznejših dejavnosti in mlajših najdb ni.<sup>57</sup>

## Orodje ali kuhinjski pripomočki

### Noži

Študij nožev rimske dobe in njihovo razvrščanje v oblikovne skupine poleg raznovrstnosti oblik močno otežujejo obrablenost, slaba ohranjenost in močna zarjavelost, zaradi česar je oblika noža drugačna od prvotne. Poleg tega so redke najdbe nožev natančneje datirane znotraj rimske dobe.<sup>58</sup> Uporaba posameznih oblik nožev razen redkih primerov ni natančneje znana - v prvi vrsti je šlo domnevno za kuhinjske pripomočke, ki so bili lahko poleg tega uporabljani tudi sicer v gospodinjstvu, v rokodelstvih in poljedelstvu. Razen izjem ni dokazov, da bi obstajala neposredna povezava med obliko in načinom uporabe noža.<sup>59</sup>

Primerjave za dobro ohranjen nož z Vodice (*sl. 10: 9*), ki bi ustrezala v vseh podrobnostih, ni bilo mogoče najti. Oblikovno sorodna, vendar drugačne velikosti, je posamična najdba noža z najdišča Runder Berg. Ta ima na rezilu, ki se proti konici oži z zgornje in spodnje strani, žleb.<sup>60</sup> Gre za tipično obliko noža pozne cesarske dobe, ki se pogosto pojavlja v germanskih grobovih 4. st., pa tudi v poznorimskih sklopih. Braniki so pri nožih tega tipa pogosti.<sup>61</sup> Dolg ročajni trn je po ugotovitvah Ursule Koch značilen za nože pozne cesarske dobe.<sup>62</sup> Zaradi pomanjkanja ustreznih primerjav noža z Vodice ne moremo natančneje opredeliti in datirati.

Nož z Vodice (*sl. 10: 10*) je po dolžini in obliki trna ter prehoda v rezilo podoben nožu s slabo ohranjenim rezilom z najdišča Oberwinterthur (*Vitudurum*) v Švici.<sup>63</sup> Nož je relativnokronološko uvrščen v periodo II najdišča, ki je omejena z letnicama 45/55 in 70/80 po Kr.<sup>64</sup> Podoben, vendar daljši je tudi nož z najdišča Augsburg-Oberhausen, ki ni natančneje datiran.<sup>65</sup> Dolg ročajni trn, domnevno značilen za nože pozne cesarske dobe,<sup>66</sup> ne zadošča za opredelitev in datacijo noža z Vodice.

Nož z Vodice (*sl. 10: 11*) predstavlja najpogostejšo obliko rimskih nožev, to je z enakomerno izbočeno ostrino rezila,

<sup>43</sup> Zadnji je dopolnil obstoječe sezname plumbat in jih kartiral Höck 2003, 69 op. 458, 71, Tab. 8, 72-73, Abb. 50, 161, Fundliste 5. Prej Völling 1991, 296-298; Degen 1992, Abb. 6; Buora 1997. Objava novega primerka (*Vindonissa*) Huber 2003, 397 in Hagendorn 2003, 668 št. Me898, Taf. 72: Me898; Kasprzyk 2004, 243, fig. 3: 4 (Escolives-Sainte-Camille); najdbe v Srbiji Christodoulou 2001-2002, 29-31, op. 19, fig. 8; 9: B-D.

<sup>44</sup> Höck 2003, 72.

<sup>45</sup> O Vegecijevem opisu Kolias 1988, 173-174; Bennett 1991, 59; Degen 1992, 140.

<sup>46</sup> Degen 1992, 144, 146; Höck 2003, 72; Christodoulou 2001-2002, 31; Buora 1997.

<sup>47</sup> Barker 1979, 97; Degen 1992, 144; Buora 1997, 240-242. Za najdbe s treh britanskih najdišč Marchant (1990, 2) dopušča datacijo v 3. st. ali pozneje. Völling (1991, 291) pa datacijo v poznorimsko dobo utemeljuje tudi z dejstvom, da *plumbatae* niso znane iz Dacije in zgornjegermansko-recijskega limesa, ki sta bila opuščena v sedemdesetih letih 3. st.

<sup>48</sup> O omembah v literarnih virih Kolias 1988, 175-177; o najdbi bizantinske različice Völling 1991, 287-288, 294-296, Abb. 1.

<sup>49</sup> Na nekaterih seznamih plumbat je omenjena tudi najdba z Martinj Hriba (Leben, Šubic 1990, 318, t. 2: 18), vendar se je pri konservatorskem posegu pokazalo, da je navadna ost kopja z zalustma.

<sup>50</sup> Valič 1985, 267, sl. 95; Valič 1997, 264, sl. 8.

<sup>51</sup> Giesler 1981, 76, 173, Katalog I/L. 9: 180, Taf. 22: 180, 76, 173, Katalog I/ L. 9: 179, Taf. 22: 179 (ohranjena je le svinčena obloga); Ciglenciki 1994a, Taf. 1: 20.

<sup>52</sup> Petru 1976, neošt. str. 36: zgoraj levo; Pflaum 2001b, 24.

<sup>53</sup> Korošec 1982, 93, t. 8: 5.

<sup>54</sup> Müllner 1900, Taf. 56: 17; Guštin 1979, 47, t. 80: 3 (objavlja jo pod napačnim najdiščem Šmihel; enako Guštin 1973, 486, sl. 3: 23 in Slapšak 1996, 220, spodnja slika: 2); Degen 1992, Abb. 4: 9; Pflaum 2001. V literaturi je najpogosteje kot najdišče navedeno ime Utik, pri čemer gre za staro poimenovanje vasi Podutik pri Ljubljani. Plumbata je bila najdena med Podutikom in Toškim celom - prim. Šašel 1975. Za opozorilo o nepravilnem imenovanju najdišča se zahvaljujem dr. Draganu Božiču.

<sup>55</sup> Bavec 2001, 169, sl. 51: 8.

<sup>56</sup> Müllner 1900, Taf. 54: 16; Guštin 1979, 47, t. 80: 4 (objavlja jo pod napačnim najdiščem Šmihel); Horvat 1990, 306, sl. 36; Pflaum 2001a.

<sup>57</sup> Bavec 2001, 166-170.

<sup>58</sup> O problematiki študija nožev Manning 1985, 108.

<sup>59</sup> Schaltenbrand Obrecht 1996, 167; Manning 1985, 108.

<sup>60</sup> Koch 1984, 213, Taf. 22: 1.

<sup>61</sup> Ib., 118, 199. Nož uvršča v svojo skupino nožev s širokim rezilom sulicaste oblike.

<sup>62</sup> Ib., 119.

<sup>63</sup> Schaltenbrand Obrecht 1996, 166-167, 326 št. E 253, Taf. 50: 253.

<sup>64</sup> Ib., 142.

<sup>65</sup> Hübener 1973, 52, Taf. 20: 22.

<sup>66</sup> Koch 1984, 119.

ravnim hrbtom rezila in ročajnim trnom, postavljenim nižje od hrpta rezila. Podobni noži so bili npr. najdeni na najdiščih *Carnuntum*,<sup>67</sup> *Walthamstow*<sup>68</sup> in *Oberwinterthur (Vitudurum)*.<sup>69</sup> Datiran je le nož z zadnjega najdišča, in sicer je relativnokronološko postavljen v periodi I/zgodaj in II najdišča. Periodi sta datirani od okoli 7 do okoli 35 po Kr. ter od 45/55 do 70/80 po Kr.<sup>70</sup> Noža z Vodic zato znotraj rimske dobe ne moremo natančneje datirati.

Nož (*sl. 10: 12*) je izjemno slabo ohranjen, zato opredeljevanje na podlagi oblikovnih primerjav ne more biti uspešno. Skoraj povsem enak, vendar krajši, se zdi nož iz *Carnunta*, najden na nasipu ceste in nedatiran.<sup>71</sup> Primerjava nič ne pripomore k opredelitvi noža z Vodic.

Noža (*sl. 10: 13,14*), ki sta skoraj povsem enake suličaste oblike med številnimi in raznovrstnimi oblikami rimskih nožev tako rekoč nimata primerjav. Podoben nož, vendar z zakovicami na ročaju, je bil najden v kastelu *Zugmantel* in bil opredeljen kot redka, posebna oblika noža za usnje.<sup>72</sup> Sam nož ni natančneje datiran, kastel *Zugmantel* pa je bil zgrajen konec 1. st. po Kr. in opuščen ob padcu *limesa leta 260* po Kr.<sup>73</sup> V Sloveniji je bil enak nož kot na *Vodicah* najden ob izkopavanjih poznorimske hiše na *Ajdovščini nad Rodikom*,<sup>74</sup> zato tudi noža z *Vodic* morda lahko datiramo v isti čas.

### Merilna priprava

#### *Tehtnica*

Razprave o antičnih tehtnicah se osredotočajo na metrološke analize (na poskuse dešifriranja in rekonstrukcije skal, na poskuse izračuna razpona nosilnosti posamezne tehtnice ter na razmerja med dolžinama ročic glede na različna vrtilišča)<sup>75</sup> ali na tipološke delitve.<sup>76</sup> Bronasta hitra tehtnica z *Vodic* (*t. 1: 15; sl. 11*) je ohranjena skoraj v celoti, vključno z utežjo, manjka le en kavelj za obešanje bremena. Trije kavlji za obešanje tehtnice na različnih mestih ročice bremena so omogočali tehtanje različno težkih bremen. Tri skale na ročici skale, prilagojene trem vrtiliščem, so različno dobro vidne. Prva skala je lepo vidna: razdeljena je na 12 enot, od 1 do 12 liber. Razmaki oznak so dolgi od 1,4 do 1,6 cm, povprečna dolžina enot je 1,51 cm. Slabo vidne oznake druge skale kažejo, da so bile enote druge skale malo več kot pol krajše od enot prve skale, povprečna dolžina enot je 0,65 cm. Če razdaljo med boljše vidnima oznakama X in V zaporedno nanesimo po ročici skale, ugotovimo, da so z drugo skalo lahko tehtali bremena, težka od 10 do 37 liber. Enak razpon dobimo tudi pri izračunu po formuli

$Tu \times Drs = Drb \times (To+Tb)$  ( $Tu$  = teža uteži [v tem primeru 1486 g oziroma 4,5 libre];  $Drs$  = dolžina ročice skale oziroma razdalja med izbrano oznako na izbrani skali in pripadajočim ušescem za obešanje tehtnice [vrtiliščem];  $Drb$  = dolžina ročice bremena oziroma razdalja med vrtiliščem in točko [utorom], kjer je obešeno breme;  $To$  = teža verižnega obešalnika [v tem primeru zanemarjena, ker obešalnik ni ohranjen v celoti in ker ga ni bilo mogoče stehtati];  $Tb$  = teža bremena [neznanka]; 1 libra = 327,45 g). Na tretji skali je slabo vidna prav izhodiščna oznaka XXX, nato se izmenjujejo bolj ali slabše vidne oznake V in X. Izračun po predstavljeni formuli razkrije razpon tretje skale od 30 do 100 liber. Enote tretje skale so bile več kot pol krajše od enot druge skale, povprečna dolžina enot je 0,27 cm, razmaki oznak odsekov po pet enot so dolgi od 1,2 do 1,4 cm. S tehtnico z *Vodic* so torej lahko tehtali bremena, težka od 1 libre do 100 liber oziroma od približno 1/3 kg do 32,7 kg.

Tehtnica zelo očitno ni ohranjena v prvotni obliki: drugotne zamenjave so srednje ušesce, srednji in desni kavelj za obešanje tehtnice in železni deli verižnega obešalnika za breme. Ohranjeni deli prvotne tehtnice oblikovno ustrezajo zgodnji skupini tipa *Osterburken*, kot ga je določil *Norbert Franken*.<sup>77</sup> Na tehtnici z *Vodic* sta dve izmed treh oblikovnih podrobnosti, ki jih je *N. Franken* uporabil kot glavne kriterije za določitev zgodnje skupine: bronasta člena verižnega obešalnika sta zvita iz dolgih kosov žice na način, da nazaj zapognjeni konec žice spiralno ovija sredino člena; levi kavelj za obešanje tehtnice ima obliko vprašaja - ravnemu delu sledi zavoj. Člen verižnega obešalnika v obliki grške črke omega ni narejen iz upognjene bronaste žice, kot je značilno za tehtnice zgodnje skupine tipa *Osterburken*, ampak je železen in sploščen s strani. Taki bronasti ploščati členi so značilni za pozno skupino tehtnic tipa *Osterburken* in za tehtnice poznoantično-zgodnjebizantinskega tipa *Konstantinopol* po tipologiji, ki jo je izdelal *N. Franken*,<sup>78</sup> podoben železen člen pa je na tehtnici z *Ljubične nad Zbelovsko Goro*<sup>79</sup> tipa *Gora*, ki ga je določil *Dragan Božič*.<sup>80</sup> S tehtnicama tipa *Gora* so primerljivi tudi tordirani železni členi verižnega obešalnika tehtnice z *Vodic*. Tretji (desni) kavelj za obešanje tehtnice z *Vodic* s spodnjim koncem, zavitim nazaj v obliki črke S, nekoliko spominja na tehtnice tipa *Konstantinopol*.<sup>81</sup>

*N. Franken* na osnovi hipotez o zgodovini razvoja tehtnic domneva, da tehtnice zgodnje skupine tipa *Osterburken* pripadajo drugi polovici 2. st. in prvi polovici 3. st., tehtnice pozne skupine pa poznejšemu 3. st.<sup>82</sup> *D. Božič* je utemeljil poznejšo datacijo pozne skupine, to je datacijo predvsem v 4. st.<sup>83</sup> Verjetno bi posledično smeli podaljšati ali prestaviti tudi datacijo zgodnje skupine v poznejši čas, morda v celotno 3. st. Tip *Gora* je hipotetično datiran v 4. st.,<sup>84</sup> tip *Konstantinopol* pa je datiran predvsem v 5. in 6. st.<sup>85</sup> Po naknadnih popravilih tehtnice z *Vodic*, ki oblikovno ustrezajo mlajšim tipom tehtnic, lahko sklepamo, da je bila tehtnica dolgo v uporabi, verjetno še vse 4. st.

Železne ali bronaste hitre tehtnice so prisotne tudi v nekaterih drugih zakladnih najdbah z ozemlja Slovenije, vendar oblikovno pripadajo drugim, mlajšim tipom. Železni hitri tehtnici novo določenega tipa *Gora* sta bili najdeni v sklopu tretje zakladne najdbe z *Gore nad Polhovim Gradcem*, datirane v drugo polovico 4. in začetek 5. st.,<sup>86</sup> in v sklopu zakladne najdbe I z *Ljubične nad*

<sup>67</sup> Nož je zelo podobne oblike, vendar krajši (*Stiglitz* 1986, 210, Taf. 10: 3 na str. 220).

<sup>68</sup> *Manning* 1985, 115, pl. 55: Q49. Opredeljen je kot tip 15 (*ib.*, 115, fig. 28: 15 na str. 109).

<sup>69</sup> *Schaltenbrand Obrecht* 1996, 326 št. E 250, Taf. 50: 250. Uvrščen je v podskupino 1 skupine I, za katero je značilen v prvi vrsti ročajni trn, nato pa raven hrbet rezila z neposrednim prehodom v trn (*ib.*, 167, Tab. 72).

<sup>70</sup> *ib.*, 142, 167, Tab. 72.

<sup>71</sup> *Stiglitz* 1986, 210, Taf. 10: 2 na str. 220.

<sup>72</sup> *Pietsch* 1983, 78, 121 št. 597, Taf. 27: 597. O podobnih nožih za usnje tudi *Gaitzsch* 1980, 122, 126, Abb. 13 na str. 123.

<sup>73</sup> *Pietsch* 1983, 6-7.

<sup>74</sup> *Slapšak* 1999, 162, slika levo spodaj: nož tik nad zvonci.

<sup>75</sup> Na primer *Mutz* 1983; *Mutz* 1988; *Garbsch* 1988, 202-209; seznam del o metroloških vprašanjih v zvezi z antičnimi tehtnicami v *Franken* 1993, op. 5.

<sup>76</sup> *Franken* 1993.

<sup>77</sup> *ib.*, 85-89, Abb. 8, 10.

<sup>78</sup> *ib.*, 87, 89-94, Abb. 11, 12: F; *Garbsch* 1988, 209.

<sup>79</sup> *Gaspari et al.* 2000, 195, Fig. 8: 15.

<sup>80</sup> *Božič* 2005, 353.

<sup>81</sup> *Garbsch* 1988, Abb. 3, Taf. 28; *Mutz* 1988, Taf. 33; *Franken* 1993, Abb. 11.

<sup>82</sup> *Franken* 1993, 89.

<sup>83</sup> *Božič* 2005, 353, 367.

<sup>84</sup> *ib.*, 353.

<sup>85</sup> *Franken* 1993, 93.

<sup>86</sup> *Božič* 2005, 351, 353, 356, 361, Abb. 20.

Zbelovsko Goro, datirane v 6. in 7. st.,<sup>87</sup> datacijo je z analogijami iz poznorimskih zakladnih najdb in s hipotetičnim datiranjem tipa tehtnice v 4. st. ovrigel D. Božič.<sup>88</sup> Dve železni in bronasta hitra tehtnica sta vsebovani v že dolgo znani domnevni zakladni najdbi z Ajdovskega gradca nad Vranjem, datirani v poznejši čas poselitve naselja (po 4. st.);<sup>89</sup> proti tako pozni dataciji bi govorile nekatere druge najdbe, na primer fibula s čebulastimi gumbi<sup>90</sup> tipa 3/4 B po Philippu M. Pröttlu, datiranega v čas od okoli 330 do okoli 400 oziroma morda predvsem v mlajši del tega razdobja.<sup>91</sup> Bronasta tehtnica z Ajdovskega gradca pripada tipu Konstantinopol, daljša železna tehtnica je glede na fotografijo<sup>92</sup> povsem podobna bronasti, krajša pa je slabše ohranjena in podrobnosti na fotografiji niso vidne.<sup>93</sup>

## Orodje

### *Bradve in sekiri*

Bradve (*t.* 2: 16-18) z Vodice se med seboj razlikujejo le v velikosti in podrobnostih (izoblikovanosti ostrine, hrbtna lista in ušesa). Vse tri imajo nazaj podaljšan spodnji del lista z ravnim zaključkom. Take in podobne bradve se večinoma pojavljajo v pozni cesarski dobi, nekateri primerki že v srednji cesarski dobi.<sup>94</sup>

Podobne, dobro datirane bradve z nizkimi pravokotnimi ojačitvenimi krilci so bile najdene na primer: tri v veliki zakladni najdbi iz Weißenburga, zakopani verjetno v drugi tretjini 3. st.,<sup>95</sup> ena v zakladni najdbi iz vodnjaka 7 vikusa Rainau-Buch, zakopani v istem času,<sup>96</sup> ena na Moosbergu, kjer je prva faza pozidave datirana v drugo polovico 3. st., druga faza pa v drugo polovico 4. st.<sup>97</sup>

Sekiri (*t.* 2: 19,20) se sicer razlikujeta v velikosti in podrobnostih, vendar se obe uvrščata v jasno zamejeno skupino rimskodobnih sekir, ki se od drugih ločijo po značilni obliki čela, podaljšane naprej in nazaj, navadno z zobci na vogalih. Najdbe tovrstnih sekir so omejene na območje Panonije, Norika in severnega Ilirika (s severovzhodnim robom Italije), drugod jih skoraj ni. Glede na okoliščine najdb se zdi, da so časovno vezane predvsem na 3. st. in poznorimsko dobo.<sup>98</sup> Sekirama z Vodice sta, na primer, podobni sekiri iz Lavriaka. Sekira, podobna sekiri (*t.* 2: 20), je bila najdena v kopalniški stavbi zahodno od civilnega mesta, ki so jo uporabljali verjetno ob koncu 2. in v začetku oziroma prvi polovici 3. st.<sup>99</sup> Sekira, podobna sekiri (*t.* 2: 19), pa prihaja z območja legijskega tabora in izvira verjetno iz 3. ali 4. st.<sup>100</sup>

V Sloveniji, ki leži tako rekoč v središču razširjenosti sekir s podaljšanim čelom, so najdbe tovrstnih sekir glede na druga območja razširjenosti izjemno pogoste. Oblikovno so večinoma podobne drugi sekiri z Vodice (*t.* 2: 20), kar pomeni, da je ozek list nesimetrično razširjen navzdol, vendar imajo na čelu zobce. Seznam najdišč tedaj znanih enajstih objavljenih in štirih neobjavljenih najdb je naredila Polona Bitenc.<sup>101</sup> Poleg tega omenja Reinhard Pohanka sekiri iz Ljubljane (*Emona*)<sup>102</sup> in z Gornjega Zemona,<sup>103</sup> Joachim Henning pa sekiro iz Orešja na Bizeljskem.<sup>104</sup> Seznamu lahko dodamo nekaj sekir s podaljšanim čelom iz zakladnih najdb orodja s teh najdišč: Sv. Pavel nad Vrtovinom (zakladna najdba, katere najdiščne okoliščine niso znane, ni natančneje datirana, naselje na Sv. Pavlu pa je obstajalo od 4. do 6. st.),<sup>105</sup> Ljubična nad Zbelovsko Goro (dve sekiri; zakladna najdba II je datirana v 3. in 4. st.),<sup>106</sup> Limberk nad Veliko Račno (datacija zakladne najdbe v čas okrog leta 400).<sup>107</sup>

Podaljšano čelo se kot oblikovna posebnost pojavlja tudi na drugem sočasnem, sekiram sorodnem orodju - na primer na bradvah in tesačah. Tovrstne bradve so bile najdene v nekaterih poznorimskih zakladnih najdbah orodja,<sup>108</sup> kot posamične najdbe pa v reki Ljubljanici in na Nanosu,<sup>109</sup> na rimski višinski postojanki druge polovice 3. st. na Velikem vrhu nad Osredkom pri Podsredi<sup>110</sup> ter na poznoantični višinski naselbini Krvavica pri Vranskem.<sup>111</sup> Tesača s podaljšanim čelom je, na primer, v zakladni najdbi z Limberka nad Veliko Račno.<sup>112</sup>

Sekire s podaljšanim čelom so se pojavljale tudi po poznorimski dobi, to je v mlajšem delu pozne antike, vendar jih je težko ločevati od rimskih.<sup>113</sup>

Glede na veliko število poznorimskih sekir s podaljšanim čelom s slovenskih najdišč (zgoraj je naštetih 24 sekir, 13 bradev in 1 tesača, kar pa zanesljivo ni popoln seznam) P. Bitenc domneva, da so jih morda izdelovali tudi nekje na območju današnje Slovenije.<sup>114</sup>

### *Tesla in kopača*

Tipologijo rimskih tesel je izdelal Martin Pietsch, deli jih na štiri tipe, ki si časovno sledijo. Tesli z Vodice (*t.* 3: 21,22) po

<sup>101</sup> Bitenc 1997, 12, z literaturo.

<sup>102</sup> Pohanka 1986, 241 op. 2. Hrani jo Umetnostnozgodovinski muzej na Dunaju.

<sup>103</sup> Ib., 241 op. 3; Božič, Ciglencečki 1995, 258 op. 94 (starejše objave).

<sup>104</sup> Henning 1987, Abb. 1: 90 na str. 61, 72 seznam; Mlinar 1965, 71, sl. 9.

<sup>105</sup> Gaspari et al. 2000, 192, 194, 196 št. 34, fig. 11: 34.

<sup>106</sup> Bitenc 2001, 14 št. 14: 7,8, sl. 14: spodnji levi dve (na skici je napaka v oštevilčenju glede na kataloške opise).

<sup>107</sup> Bitenc, Knific 2001a, 32 št. 87: 16. V isti zakladni najdbi sta tudi odlomka sekirastega orodja z ohranjenim podaljšanim čelom in delom ušesa (št. 87: 61,62). Kakšne oblike sta bila lista (sekira, bradva ali tesača), ni mogoče sklepati.

<sup>108</sup> Seznam devetih bradev s petih najdišč v Sloveniji pri Božič 2005, 313.

<sup>109</sup> Bitenc 2001a, 14 št. 13.

<sup>110</sup> Ciglencečki 1990, 150 št. 25, 152, t. 3: 4.

<sup>111</sup> Krempuš 2000, 213 št. 2, Abb. 3: 2 na str. 216. Bradvo na podlagi primerjav datira v pozno 3. in zgodnje 4. st. Tudi Bitenc 2001b.

<sup>112</sup> Bitenc, Knific 2001a, 32-33 št. 87: 24, sl. 87: 24.

<sup>113</sup> Podatke o mlajših sekirah s podaljšanim čelom in možnostih ločevanja od rimskodobnih mi je ustno posredovala Polona Bitenc (Narodni muzej Slovenije), za kar se ji na tem mestu še enkrat zahvaljujem. O načinu izdelave sekir Pleiner 1967, 79-83, Abb. 1 na str. 80; Bitenc 1997, 4-5.

<sup>114</sup> Bitenc 1997, 23.

<sup>87</sup> Gaspari et al. 2000, 192, 200, št. 15, 16, Fig. 8: 15,16; Gaspari 2001, 58.

<sup>88</sup> Božič 2005, 356.

<sup>89</sup> Riedl, Cuntz 1909, 3-5, 34, Fig. 5: a-d; 6; 7.

<sup>90</sup> Ib., Fig. 5: k; Knific 1979, 748, sl. D.

<sup>91</sup> Pröttel 1988, 359, 361-364.

<sup>92</sup> Riedl, Cuntz 1909, Fig. 5: b.

<sup>93</sup> Ib., Fig. 5: c.

<sup>94</sup> Pietsch 1983, 15, Abb. 5: 2.

<sup>95</sup> Kellner, Zahlhaas 1983, 48, 43 št. 99-101, Abb. 32.

<sup>96</sup> Kaufmann-Heinimann 1998, 272 št. GF61, Abb. 234.

<sup>97</sup> Garbsch 1966, 72, 85, Taf. 22. 19; 31: 13.

<sup>98</sup> Pohanka 1986, 229, 239-242, Textabbildung 14: Typ 3; nekoliko pomanjkljiv zemljevid razširjenosti tovrstnih sekir in bradev je objavil Henning 1987, 61, 64, Abb. 1 na str. 61, 72-73 seznam najdišč; Bitenc 1997, 11-12, 28-29, št. 33-38, sl. 4 na str. 12, sl. 33-38.

<sup>99</sup> Pohanka 1986, 240-241, 376 št. 199, Taf. 45: 199.

<sup>100</sup> Ib., 240-241, 376 št. 198, Taf. 45: 198.

opisu ustrežata poznorimskemu tipu IV, za katerega so značilni zaobljeno upognjen list, včasih konkavni stranici lista, včasih skoraj pravi kot med listom in (neohranjenim) toporiščem ter nizko uho (ne tulasto) z luknjo različnih oblik - okrogle, ovalne, štirikotne. Datira jih v čas od leta 260 do okrog leta 400.<sup>115</sup>

Tesla podobnih oblik so bila najdena tudi na nekaterih drugih poznorimskih najdiščih Slovenije - na primer v zakladnih najdbah orodij z Grdavovega hriba pri Radomljah,<sup>116</sup> Ljubične nad Zbelovsko Goro II<sup>117</sup> in s Sv. Pavla nad Vrtovinom.<sup>118</sup>

Dvostrano teslo (*t. 3: 23*) z Vodic ima enako obrnjena lista, prvega z ravnim, drugega z zaobljeno izbočenim rezilom. Najdbe dvostranih tesel so izjemno redke, pojavljajo pa se na najdiščih rimskih provinc.<sup>119</sup> Dobra primerjava teslu z Vodic je bila najdena v Spodnji Avstriji v zakladni najdbi z oznako Mannersdorf II; njen zakop je datiran v 4./5. st.<sup>120</sup>

Kopače z rogljema in listom v obliki motike (*t. 3: 24*) so pogosto rimsko orodje in se razlikujejo predvsem v obliki in zakrivljenosti rogljev, obliki in upognjenosti lista ter obliki ušesa.<sup>121</sup> Redke kopače so dobro datirane, na območju rimskih provinc se pojavljajo nepretrgoma od zgodnje do pozne rimske dobe.<sup>122</sup> Oblikovno sta kopači z Vodic najbližji najdbi z ožjim listom iz poznorimske zakladne najdbe iz Celja<sup>123</sup> in iz Saalburga.<sup>124</sup>

#### Drugo orodje

Kladivo z Vodic (*sl. 12: 25*) je kot tip orodja podobno skupini maloštevilnih domnevnih rimskih kladiv s čelom in razcepjenim kljunom, namenjenim izvleku žebjev.<sup>125</sup> Kladiva z razcepjenim kljunom je mogoče odkriti na rimskodobnih najdiščih različnih stoletij, vendar jih na podlagi oblikovnih razlik ni mogoče natančneje datirati. Podobna so tudi tovrstna srednjeveška kladiva.<sup>126</sup>

Kladivo z Vodic med sorodnimi domnevno rimskodobnimi kladivi nima primerjave, ki bi se jemala tudi v podrobnostih, ne le kot tip orodja. Glede na okroglo obliko čela in izoblikovanost enega kraka v trikotno konico, kar je značilnost tesarskih kladiv še polpretekle dobe,<sup>127</sup> je najverjetneje, da je kladivo z Vodic srednje- ali novoveško.

<sup>115</sup> Pietsch 1983, 27-28, Abb. 11: 2, Abb. 26 na str. 81.

<sup>116</sup> Sagadin 2000, pl. 2: 1-3; Sagadin 2001, 15 št. 15: 16,19,20, sl. 15: 16,19,20. Zakladno najdbo datira le okvirno v drugo polovico 3. in 4. st., Božič (2005, 313) pa domneva datacijo v čas okrog leta 400.

<sup>117</sup> Bitenc 2001, 14 št. 14: 5, sl. 14: sredina-desno (oštevilčenje na skici je glede na kataloške opise zamešano).

<sup>118</sup> Gaspari et al. 2000, 192, 194-195 št. 25, 27, 196 št. 33, fig. 10: 25,27; 11: 33.

<sup>119</sup> Gaitzsch 1980, 45-46.

<sup>120</sup> Pollak 2006, 25-26, 31, 39, Abb. 35, Taf. 56: 34.

<sup>121</sup> Pietsch 1983, 19-20; White 1967, 66-68 (skupina 12. (ii) *Ascia/rastrum*), fig. 43 na str. 67; Rees 1979, 309-310 (iii. *Ascia-Rastrum*), fig. 85-87.

<sup>122</sup> Rees 1979, 310.

<sup>123</sup> Gaspari et al. 2000, 190 št. 1, fig. 6: 1.

<sup>124</sup> Pietsch 1983, 90 št. 68, Taf. 5: 68.

<sup>125</sup> Gaitzsch 1980, 88, 90-91 (naštetih nekateri primerki), 350 št. 84 (kladivo iz Pompejev), Abb. 9 na str. 81, Taf. 9: 84 oz. 16: 84; Pietsch 1983, 24, 91 št. 106, Taf. 7: 106.

<sup>126</sup> Na primer z najdišča Runder Berg (Koch 1984, 136, 222, Taf. 35: 1).

<sup>127</sup> Za informacijo o obliki nedavnih tesarskih kladiv s koničastim krakom se zahvaljujem dr. Draganu Božiču.

*Železno rezilo* (*t. 3: 28*) sodi v ozko skupino skoraj povsem enako oblikovanih ukrivljenih rezil s trnom na enem in ploščatim podaljškom z zanko na drugem koncu. Namembnost rezil dolgo ni bila znana, najpogosteje so bila na podlagi domnevne uporabe opredeljena kot rezila za krmo ali podobno (nem. *Futterschneidermesser*),<sup>128</sup> sicer pa uvrščena v razne skupine orodij - na primer v skupino vejnikov in podobnih rezil.<sup>129</sup> Heimo Dolenz<sup>130</sup> in Milan Sagadin<sup>131</sup> pa sta, prvi na podlagi upodobitve orodij sodarja na nagrobni steli iz Akvileje, drugi na podlagi etnoloških primerjav iz Nizozemske (noži za izdelavo cokel), dokazala, da so bila tovrstna rezila namenjena obdelavi lesa oziroma izdelavi lesenih predmetov. Rezilo je bilo na trdno podlago pritrjeno prek zanke,<sup>132</sup> kar je omogočalo premikanje v vse smeri, in ne prek trna.<sup>133</sup>

Najdbe rezil za obdelavo lesa so znane predvsem iz severovzhodnih provinc rimskega imperija in severovzhodnega dela Italije (to je vzhodnoalpski in panonski prostor). Večina jih je na podlagi najdiščinih okoliščin datiranih v poznorimski čas,<sup>134</sup> pravih argumentov za poznejšo in zgodnejšo datacijo posameznih primerkov ni (H. Dolenz omenja zgodnejši najdbi iz Viruna in že omenjeno upodobitev na steli iz Akvileje, datirani v 2. st.).<sup>135</sup>

S slovenskih najdišč so bili v strokovni literaturi objavljeni trije primerki tovrstnih rezil. Rezilo z Ajdovskega gradca nad Vranjem, ki ima v zanki ploščatega podaljška še ohranjen obroček za pritrnitev na trdno podlago, je bilo najdeno v hiši A z drobnimi najdbami iz časa od 3./4. st. do 6. st.<sup>136</sup> Rezilo z Grdavovega hriba pri Radomljah je bilo del zakladne najdbe orodij, okvirno datirane v čas od druge polovice 3. do konca 4. st.<sup>137</sup> oziroma ožje v čas okrog leta 400.<sup>138</sup> Tretje rezilo je bilo najdeno na Limberku nad Veliko Račno, prav tako v sklopu zakladne najdbe orodij in orožja. Zakladna najdba je datirana v čas okrog leta 400.<sup>139</sup> Četrto rezilo je bilo odkrito leta 2003 v sklopu zakladne najdbe z Gradišča pri Trnovem v Ilirski Bistrici, ki še ni objavljena.<sup>140</sup>

*Sveder* z Vodic (*t. 4: 29*) se uvršča med tako imenovane žličaste svedre, ki so najpogostejša oblika rimskodobnih svedrov. Njihovo tipologijo je izdelal M. Pietsch na podlagi oblik žličke in nasadila ter ugotovil, da so žličke z največjo širino pod sredino svoje dolžine običajne na svedrih zgodnje in srednje cesarske dobe, pojavljajo pa se tudi še v pozni antiki, žličke z največjo širino nad sredino svoje dolžine pa se pojavljajo skoraj izključno na svedrih iz poznoantičnih in nerimskih sklopov. Glede nasadil je prepoznal razvoj od širokih trikotnih, jasno ločenih od držaja v zgodnji in srednji cesarski dobi, do ozkih daljših, manj ostro ločenih od držaja v pozni cesarski dobi.<sup>141</sup> Nasadilo svedra z Vodic ustreza opisu nasadil pozne

<sup>128</sup> Na primer Pohanka 1986, 265-267, 383 št. 232, Taf. 50: 232, Textabbildung 18/zgoraj; Knific 1979, 741-742 (slamozreznica).

<sup>129</sup> Popović 1988, 81, t. 13: 5 oz. 44: 4; Müller 1982, 340 št. 1491, sl. 24: II.2 na str. 506, 410 št. 1996, 831.

<sup>130</sup> Dolenz 1998, 208.

<sup>131</sup> Sagadin 2000, 205, fig. 1; Sagadin 2000a, 560.

<sup>132</sup> Knific 1979, 741; Sagadin 2000, 205.

<sup>133</sup> Na primer Pohanka 1986, Textabbildung 18/zgoraj.

<sup>134</sup> Pohanka 1986, 265.

<sup>135</sup> Dolenz 1998, 208.

<sup>136</sup> Knific 1979, 733 št. 18, 741-742, 750, sl. 18 na str. 765; Knific 2001, 52 št. 146.

<sup>137</sup> Sagadin 2000, 205-206, pl. 2: 6; Sagadin 2001, 14-15 št. 15: 3, sl. 15: 3.

<sup>138</sup> Božič 2005, 313.

<sup>139</sup> Bitenc, Knific 2001a, 32 št. 87: 17.

<sup>140</sup> Božič 2005, 313-314 op. 18.

<sup>141</sup> Pietsch 1983, 43-44.



cesarske dobe, žlička pa je najširša pod širino svoje dolžine in torej ustreza žličkam, ki so običajnejše na svedrilih zgodnje in srednje cesarske dobe, pojavljajo pa se tudi še pozneje. Okrogli presek stebila, kot ga ima sveder z Vodice, je redek, pogostejši je osmerokoten ali kvadraten.

V Sloveniji se žličasti svedrili redno pojavljajo v poznorimskih in poznoantičnih naseljih ter zakladnih najdbah orodja - na primer v zakladni najdbi orodja I z Ljubične nad Zbelovsko Goro,<sup>142</sup> v zakladni najdbi orodja iz Celja, najdeni v veliki stavbi s hipokavstom iz 4. st.,<sup>143</sup> pet primerkov v zakladni najdbi z Grdavovega hriba pri Radomljah,<sup>144</sup> pet primerkov v zakladni najdbi z Limberka nad Veliko Račno,<sup>145</sup> na poznoantični višinski naselbini Krvavica pri Vranskem,<sup>146</sup> na poznoantični višinski naselbini na Tonovcovem gradu pri Kobaridu,<sup>147</sup> po dva primerka na poznoantični višinski naselbini Ajdovski gradec nad Vranjem<sup>148</sup> in poznorimski utrjeni postojanki Ančnikovo gradišče pri Jurišni vasi,<sup>149</sup> po dva primerka svedrilo z Vodice podobne oblike sta bila izkopana tudi v Drnovem pri Krškem (*Neviodunum*)<sup>150</sup> in na Ajdovščini nad Rodikom.<sup>151</sup> Nasadila vseh naštetih svedrov ustrezajo Pietschevemu opisu nasadil pozne cesarske dobe. Nasprotno pa večina žličk naštetih svedrov (kolikor je bilo moč razbrati z objavljenih risb in fotografij) doseže največjo širino pod sredino svoje dolžine, kar naj bi bilo po Pietschevih ugotovitvah običajnejše, ne pa izključno, na svedrilih zgodnje in srednje cesarske dobe. Na poznorimskih svedrilih s slovenskih najdišč žlička z največjo širino pod sredino svoje dolžine izrazito prevladujejo,<sup>152</sup> zato lahko sklepamo, da je taka oblika povsem običajna tudi v pozni cesarski dobi in da mesto največje širine žlička ni ustrezen kriterij za kronološko opredelitev svedrov.

*Železno šestilo z Vodice (t. 4: 30)* se po obliki osi uvršča v skupino antičnih šestil s kratko osjo, na obeh straneh izbočeno v nizko glavico ali na prvi strani sploščeno, na drugi izbočeno. Drugo skupino predstavljajo šestila, pri katerih je skozi os, na eni strani podaljšano, zataknjen zatič, namenjen fiksiranju krakov ob uporabi.<sup>153</sup> Po dolžini (36,4 cm) je šestilo z Vodice med daljšimi.

Železna in bronasta šestila se pojavljajo v vsem rimskem cesarskem obdobju, vendar njihov oblikovni spekter in kronološki razvoj še nista bila raziskana.

V Sloveniji je bilo nekaj primerkov, sorodnih šestilu z Vodice, najdenih v poznorimskih sklopih najdb, pogosto zakladnih najdbah železnega orodja.<sup>154</sup> Večina najdb je podobne dolžine (nad 30 cm) kot šestilo z Vodice in ima enako oblikovane krake, v podrobnostih pa se razlikuje od njega - ploščice so okrogle,

<sup>142</sup> Gaspari et al. 2000, 191-192 št. 13, fig. 7: 13; Gaspari 2001, 58 št. 168; Božič 2005, 356.

<sup>143</sup> Gaspari et al. 2000, 190 št. 10, fig. 7: 10 na str. 194.

<sup>144</sup> Sagadin 2000, pl. 1: 1-5; Sagadin 2001, 15 št. 15: 11-15, sl. 15: 11-15; Božič 2005, 313.

<sup>145</sup> Bitenc, Knific 2001a, 32-33 št. 87: 31,33,34,49,50, sl. 87: 31,33,34,49,50.

<sup>146</sup> Krempuš 2000, 219 št. 48, Abb. 5: 48 na str. 222. Sveder je datiran le v čas obstoja naselbine, to je od sredine 3. do konca 6. stol. po Kr. Tudi Bitenc 2001b.

<sup>147</sup> Ciglencečki 1994, 7, t. 4: 7.

<sup>148</sup> Ciglencečki 1994a, Taf. 8: 11; Knific 2001.

<sup>149</sup> Strmčnik 1997, 281 št. 7, 8, t. 6: 7,8.

<sup>150</sup> Petru, Petru 1978, 66, t. 21: 1,14.

<sup>151</sup> Slapšak 1997, 58, sl. 9: druga vrsta levo.

<sup>152</sup> Le svedrili z Limberka nad Veliko Račno so drugačni, vsaj nekateri izmed njih imajo žličke, najširše nad sredino svoje dolžine.

<sup>153</sup> Manning 1985, 11-12; Pietsch 1983, 61.

<sup>154</sup> Seznam najdb šestil s slovenskih najdišč v Murgelj 2000, 55-56.

os pa je navadno podaljšana in prebodena z zatičem. Taka šestila so bila najdena na primer v zakladni najdbi orodja z Grdavovega hriba pri Radomljah,<sup>155</sup> v zakladni najdbi orodja in orožja z Limberka nad Veliko Račno,<sup>156</sup> v zakladni najdbi orodja z Merišča pri Povirju, najdeni v stavbi, datirani v drugo polovico 4. st.,<sup>157</sup> in v zakladni najdbi orodja I z Ljubične nad Zbelovsko Goro.<sup>158</sup>

*Nakovalo z Vodice (t. 4: 31; sl. 13)* sodi med preprosta, tako imenovana blokovna nakovala italskega tipa po W. H. Manningu oziroma med nakovala tipa B po Wolfgangu Gaitzschu (podrobnejša tipološka delitev nakoval). Gre za razmeroma majhna samostojno stoječa nakovala kvadraste ali kockaste (tip B po W. Gaitzschu) oblike, ki se rahlo ožijo proti nekoliko vbočeni spodnji ploskvi, s čimer so v vogalih nastale štiri majhne nogice, na katerih je nakovalo stalo.<sup>159</sup> Blokovna nakovala z nogicami so znana na primer iz Pompejev, z nagrobnega reliefa iz Akvileje s prizorom iz kovačnice<sup>160</sup> in iz Sarmizegetuse Regie v Romuniji.<sup>161</sup> Tip nakovala je bil očitno prisoten že v zgodnji rimski dobi oziroma v 1. st., opor za natančnejšo datacijo tipa in časovno omejitvev njegovega obstoja znotraj rimske dobe zaenkrat ni.

### Konjska oprema in deli vozov

#### *Obuvala kopit (hiposandale)*

Vseh pet primerkov obuval kopit oziroma hiposandal z Vodice (*sl. 14; 15*) je enake oblike, približno enake velikosti in nekoliko različnih tež, odvisno od masivnosti. Obuvala oblikovno pripadajo tipu 1 izmed treh tipov po Annabel K. Lawson oziroma Xavieru Aubertu.<sup>162</sup> Obuvala kopit so datirana, kjer najdiščni sklopi datacijo sploh dopuščajo, večinoma v čas med sredino oziroma drugo polovico 1. in koncem 4. st.<sup>163</sup> Mlajši primerki niso znani, v starejši (avgustejski) čas pa so datirani redki primerki, na primer s Štalenske gore.<sup>164</sup> Kronološki razvoj obuval kopit glede na tipe še ni bil raziskan. Bežen pogled v nekatere zakladne najdbe kovinskih predmetov 3. st., ki vsebujejo obuvala kopit, pokaže, da gre v vseh primerih za obuvala tako imenovanega tipa 3,<sup>165</sup> nikoli tipa 1.

<sup>155</sup> Sagadin 2000, 205, pl. 1: 9; Sagadin 2001, 15 št. 15: 24, sl. 15: 24; Božič 2005, 313.

<sup>156</sup> Bitenc, Knific 2001a, 32-33 št. 87: 58, sl. 87: 58.

<sup>157</sup> Osmuk 1976, 82, 78 št. 29, t. 4: 7. Šestilo ima ploščici izbočeno zaobljene trikotne oblike, kar je najbližje šestilu z Vodice. Gaspari et al. 2000, 187 zakladno najdbo datirajo v 4. st.

<sup>158</sup> Gaspari et al. 2000, 191-192 št. 11, 198, fig. 7: 11; Gaspari 2001, 58 št. 168; Božič 2005, 356.

<sup>159</sup> Manning 1985, 1, fig. 1: 1 (nakovalo z Vodice povsem ustreza njegovemu opisu italskega tipa nakoval); Gaitzsch 1978, 16, sl. na str. 4; Gaitzsch 1985, 179, Abb. 3 na str. 192: tip B, seznam na str. 201.

<sup>160</sup> Gaitzsch 1980, 341 št. 8, Taf. 2: 8, 365 št. 199, Taf. 43: 199a.

<sup>161</sup> Popescu 1997, 267 št. 545; Iaroslavschi 1997, 71, pl. 29: 3. Nakovalo ni datirano.

<sup>162</sup> Lawson 1978, 133-135, Abb. 1 (tu sta zamenjana tipa 1 in 2: v prvi vrsti je upodobljen tip 2 z oznako tip 1, v drugi vrsti pa tip 1 z oznako tip 2!); Manning 1985, 63-66, fig. 16 (obstoječi tipologiji je dodal še dva tipa); Junkelmann 1992, 88, Abb. 100.

<sup>163</sup> Lawson 1978, 136; Manning 1985, 65; Junkelmann 1992, 88.

<sup>164</sup> Dolenz 1998, 96-97 op. 404, Taf. 22: M244.

<sup>165</sup> Na primer Mautern, zakladna najdba kovinskih predmetov, datirana v 3. st. (Groh, Sedlmayer 2006, 512-525, Taf. 264: 1699/42); Straubing, zakladna najdba kovinskih predmetov,

Domnevamo lahko, da se je v tem času verjetno uporabljal tip 3 in da je tip 1 starejši.<sup>166</sup>

Najdbe obuval kopit so številne, večinoma v severozahodnih provincah imperija, to je v severni Galiji (šlo naj bi za galsko iznajdbo) in Britaniji, pa tudi v južni Galiji ter provincah ob Renu in Donavi, zelo redke so v sredozemskem območju. Slika razširjenosti odraža tudi stanje raziskav oziroma pozornost, namenjeno tovrstnim predmetom.<sup>167</sup>

Železna obuvala kopit, za katera se je v 19. st. uveljavil angleški izraz *hipposandals*, so Rimljani imenovali *solea ferrea*. O tem, kaj je bil njihov osnovni namen in kdo jih je v prvi vrsti nosil, so bila izražena različna mnenja.<sup>168</sup> Najverjetneje se zdi, da je bil prvi namen obuval kopit varovanje kopit pred obrabo in poškodbami na trdih tleh (skalnata tla, grušč, prod, trd tlak). Konice ali žlebovi na spodnji strani podplata so dodatno varovali žival pred zdrsom na spolzkih tleh, snegu in ledu.<sup>169</sup> Precej manj verjetna je razlaga, da je šlo za veterinarski pripomoček, ki je na poškodovanem kopitu držal na mestu obvezo z morebitnimi zdravili.<sup>170</sup> Uporaba železnega obuvala v veterinarski praksi je pri antičnih avtorjih omenjena le enkrat, ob zdravljenju bolečin v kolku oziroma kolčne ohromelosti konja. V železno obuvalo so obuli zdravo nogo ob bolni, da je bil konj nekoliko privzdignjen in s tem bolna noga razbremenjena teže.<sup>171</sup>

Obuvala kopit so bila namenjena predvsem vprežnim in tovornim živalim, le izjemoma jezdnim, saj so omogočala le okorno in počasno hojo. Med vprežnimi in tovrstnimi živalmi so prevladovala mule, poleg volov in oslov ter redko konjev.<sup>172</sup> Obuvala kopit oziroma tako imenovane hiposandale so na kopito, prej ovito z blagom, torej natikali predvsem mulam in oslom, redko konjem, zato se pojavljajo v različnih velikostih.<sup>173</sup> Govedu so bila namenjena železna obuvala drugačne oblike, prilagojene nogi z dvema prstoma in torej dvema ločenima parkljema, ki so ju zaradi gibljivosti ločeno obuvali.<sup>174</sup>

V Sloveniji so obuvala kopit znana tudi z drugih najdišč, objavljenih je na primer nekaj starih najdb tipa 1.<sup>175</sup>

zakopana najverjetneje v 3. st. (Keim, Klumbach 1951, 38 št. 56-62, Taf. 43: 56-62); Welzheim, zakladna najdba železnih predmetov, datirana v 1. polovico 3. st. (Mössle 1983, 374, Taf. 208: 1-3); Weißenburg, zakop zakladne najdbe je datiran v leto 254 ali 233 (Kellner, Zahlhaas 1993, 124 št. 94, 146, Taf. 107).

<sup>166</sup> Za namig glede možne datacije obeh tipov obuval kopit se zahvaljujem dr. Draganu Božiču.

<sup>167</sup> Npr. Lawson 1978, 136, Abb. 2 na str. 135, Liste 1 na str. 161-167; Junkelmann 1992, 88; Feugère, Thauré, Vienne 1992, 88-89 št. 171-179, z navedeno literaturo o novih najdbah v južni Galiji; Feugère, Tendille 1989, 152-153, fig. 109 (dopolnjen seznam in zemljevid najdišč A. Lawson); Garbsch 1986, 78-79, seznam najdb iz Bavarske; Manning 1985, 63-66; Ruprechtsberger 1975, 25-27, 36, Abb. 1 na str. 26, najdbe iz Gornje Avstrije; Pöll, Nicolussi, Oegg 1998, 63, Abb. 12: 3; Schaltenbrand Obrecht 1996, 156-157, 323 št. E 138-141, Taf. 44: 138-141; Müller 1982, 837, 168 št. 726, 727.

<sup>168</sup> Različne razlage in razloge za ali proti natančno predstavlja Junkelmann 1992, 89; tudi Lawson 1978, 133.

<sup>169</sup> Lawson 1978, 133; Junkelmann 1992, 89; Ruprechtsberger 1975, 26; Manning 1985, 63.

<sup>170</sup> V zadnjem času razlago dopuščata na primer Dixon, Southern 1992, 231, podnapis k fig. 82 na str. 231. Razlogi proti: Lawson 1978, 133; Junkelmann 1992, 89. Antični avtorji omenjajo pri zdravljenju poškodb podobna obuvala (*solea sparteae*), narejena iz lažjih materialov, ne železa (Walker 1973, 322).

<sup>171</sup> Walker 1973, 322-323.

<sup>172</sup> Toynbee 1973, 152, 161-162, 175-176, 185, 191, 194-195.

<sup>173</sup> Lawson 1978, 133; Junkelmann 1992, 90.

<sup>174</sup> Brouquier-Reddé 1991.

<sup>175</sup> Müllner 1900, Taf. LVI: 18; Petru 1972, 130 št. 56-58,

## Podkvi

Podkvi z Vodic (*sl. 16*) sta enake oblike - tanki in široki, z rahlo privzdignjenim zunanjim robom in krakoma, ki se enakomerno širita proti koncu, na krakih so po štiri luknje za žeblje. Oblika je v strokovni literaturi navadno imenovana kot podkev s krakoma v obliki luninega krajca (nem. *Hufeisen mit Mondsichelruten*) in je poleg podkev z valovitim zunanjim robom (nem. *Hufeisen mit Wellenrand*) najpogosteje opredeljena kot rimskodobna.<sup>176</sup>

Dolgotrajna diskusija o tem, ali so Rimljani poznali podkve, se do nedavnega še ni zdelo rešena, saj so se podkve vedno znova pojavljale v očitno rimskih (in redkeje tudi predrimskih) plasteh in sklopih najdb.<sup>177</sup> Končno je obstoj podkev v predrimski in rimski dobi prepričljivo ovrgel Walter Drack.<sup>178</sup> Na podlagi izkopavanj rimske in nad njo novodobne ceste v Oberwinterthuru (*Vitudurum*) v Švici je dokazal, da so podkve v rimske sloje ceste zašle pozneje, saj je bilo rimsko cestišče v uporabi vse v 18. st. (konjem so se noge pogrezale v nevzdrževano nasuto cestišče, pri čemer so pogosto izgubili podkve, ki so pozneje zaradi teže lahko potonile še globlje).<sup>179</sup> Podkve je zato opredelil tipološko, na podlagi primerjav iz dobro datiranih sklopov najdb z malih srednje- in novoveških gradov Švice. Obe obliki podkev, najpogosteje opredeljeni kot rimski, sta se pokazali za tipično srednjeveški oziroma zgodnjenovoveški: podkve z valovitim zunanjim robom so datirane v čas od 10. do 13./14. st., podkve s kraki v obliki luninega krajca pa v čas od 13./14. do 15./16. st. Podkve kot vrsta zaščite kopit pa so se pojavile v 10. ali najzgodneje 9. st.<sup>180</sup> Nesporni argumenti W. Dracka predvsem zaradi številčnosti vedno novih najdb podkev v tako imenovanih rimskih plasteh vendarle niso prepričali vseh, zato se pomisleki in dokazovanje nasprotnega nadaljujejo.<sup>181</sup>

Na podlagi ugotovitev W. Dracka lahko podkvi z Vodic okvirno postavimo v obdobje od 13./14. do 15./16. st.

## Sornik

Železen zatič (*t. 4: 39*) cilindrične oblike s ploščato pravokotno glavo je verjetno sornik štirikolesnega rimskega voza. Gre za del voza, ki je bil navpično zasajen v sredino prednje osi, da je omogočal ločljivo povezavo in obračanje prednjega dela voza (prednja os in oje) ločeno od zadnjega dela (sora in zadnja os) in nadvozja. Leseni deli voza okoli sornika so bili zaradi trenja in obremenitev pogosto ojačani z železnimi okovi raznih oblik.<sup>182</sup>

t. XCI: 1-3; Horvat 1990, 289 št. 492, t. 24: 5; Müller 1982, 168 št. 726, 727.

<sup>176</sup> Junkelmann 1992, 93-94, Abb. 103/spodaj.

<sup>177</sup> V prid rimskim podkvam na primer Lawson 1978, 137-140, Abb. 3 na str. 138 (zemljevid razširjenosti), Liste 2 na str. 167-172 (obsežen seznam); Ruprechtsberger 1975, 27-35; Manning 1985, 63 op. 1; Garbsch 1986, 79, 82, dopušča dvom; neodločeno Dixon, Southern 1992, 232-233; gl. tudi recenzijo njune knjige (Junkelmann 1993, 487); Müller 1982, 837-838, proti obstoju rimskih podkev; podrobna predstavitev diskusije in argumenti proti rimskim podkvam pri Junkelmann 1992, 92-98.

<sup>178</sup> Drack 1990.

<sup>179</sup> *Ib.*, 204-205.

<sup>180</sup> *Ib.*, 206-207.

<sup>181</sup> Na primer Alföldy-Thomas 1993, 339-343, Taf. 548: G 43-45; 549: G 46-47; 550: G 48-50; neodločeno Höck 2003, 73 op. 480, z literaturo o nedavnih najdbah in diskusiji.

<sup>182</sup> Garbsch 1986, 61-63; Venedikov 1960, 8-29, predvsem 10-11 št. 7, 22 št. 34, 78-79, tabl. 1; 2: 5; 4: 9-11; 10; 13: 40; 59; 76-79; Visy 1993, 279-283, Taf. 435: F 133-136; 436: F 138-139; 437: F 137,140-142.

Sorniku enak zatič je bil včasih navpično zasajen tudi v zadnjo os štirikolesnega voza in lesene dele nad njo, vendar je bil navadno krajši, saj v nasprotju s sornikom na vrhu ni predrl dna voza.<sup>183</sup> Zatič enake oblike, vendar navadno nekoliko daljši ali precej krajši (dolg 10-20 cm), je pri nekaterih vozovih ležal vodoravno pred prednjo osjo, kjer je povezoval lesene dele ob ojesu,<sup>184</sup> ali na enakem mestu pred zadnjo osjo, kjer je povezoval lesene dele ob sori (*sl. 17*).<sup>185</sup> Ker sta obe vrsti zatičev zelo redki in navadno drugačne dolžine, se zdi najverjetneje, da gre pri zatiču z Vodice za sornik, čeprav nespornega dokaza ni. Pri dvokolesnih vozovih je bil na mestu sornika podoben zatič, vendar ne nujno okroglega preseka, saj vrtenje oziroma obračanje okrog njega ni bilo potrebno.<sup>186</sup>

Sorniki so bili debeli 2-4 cm in dolgi od 45 do 70 cm, vendar so pogosto na koncu odlomljeni.<sup>187</sup> V celoti ohranjeni primerek z Vodice je med daljšimi, saj meri 62,3 cm. Luknja v ostenju konca je bila namenjena razcepki.

Sornike rimskodobnih vozov je težko ožje datirati, saj se konstrukcija vozov v rimski dobi ni dosti spreminjala. Tračanski tumuli rimskega časa s tovrstnimi vozovi, ki jih je podrobno raziskal in rekonstruiral Ivan Venedikov, so na primer datirani od konca 2. do vključno prve polovice 4. st.<sup>188</sup> Gre za datacijo nekega pogrebne običaja, ki pa seveda ne izključuje obstoja vozov zunaj grobov v zgodnejšem in poznejšem času. Dobro ohranjen voz s sornikom in še dvema podobnima zatičema je bil izkopan v rimski vili v Stabiah, zasuti ob izbruhu Vezuva leta 79.<sup>189</sup> Šest tovrstnih kratkih zatičev in deset dolgih zatičev oziroma sornikov je bilo najdenih v sklopu alamanskega plena, potopljenega v Renu pri Neupotzu najverjetneje v letih 277/8, v uporabi pa so bili domnevno v srednjih desetletjih 3. st.<sup>190</sup> Le en primerek iz Neupotza ima enako oblikovano glavo kot sornik z Vodice, sicer so običajne ploske okrogle ali polkroglaste glave.<sup>191</sup>

V Sloveniji so najdbe sornikom sorodnih zatičev omejene na zakladne najdbe železnih predmetov poznorimskega časa, po sestavi podobne sklopu najdb z Vodice. Dva primerka sta v zakladni najdbi z Limberka nad Veliko Račno, datirani v čas okrog leta 400.<sup>192</sup>

### Drugo

*Šilo* z Vodice (*t. 4: 40*) sodi po obliki v skupino šil, ki se s časom niso spreminjala in so bila najpogostejša v pozni antiki. Tovrstna šila se pojavljajo v grobovih, na naselbinskih najdiščih in v zakladnih najdbah. Razlikujejo se v masivnosti in so bila

<sup>183</sup> Miniero 1987, 189 št. 29, 191, fig. 18 na str. 190; Visy 1993, Abb. 12 na str. 292 in 293.

<sup>184</sup> Mráv 2005, 37-48, 21 op. 1 - seznam literature o rekonstrukcijah rimskih vozov; Venedikov 1960, 23 št. 41, tabl. 20: 33; 12: 37; 77-78 (zatič je dolg 65 cm, ima polkroglasto glavo, detajli niso vidni, omenjena je 4 mm široka luknjica na koncu); Miniero 1987, 183 št. 11, fig. 11 na str. 184 (zatič je dolg 73 cm, ima polkroglasto glavo in sploščen konec, v katerega je vdrt nesklenjen obroč); Visy 1993, 281-282, Abb. 12/spodaj na str. 293, Taf. 431: F 124-129 (zatiči so dolgi od 10 do 20 cm).

<sup>185</sup> Visy 1993, Abb. 12/spodaj na str. 293.

<sup>186</sup> Venedikov 1960, 30-31 št. 85, tabl. 23: 72; 80. Štirirobi zatič dvokolesnega voza iz Teleca v Bolgariji se je proti koncu ožil v konico, ki je bila zapognjena.

<sup>187</sup> Garbsch 1986, 61; Visy 1993, 280, 282-283; Manning 1985, 126, pl. 58: R6; Hübener 1973, 43, Taf. 15: 1,6,14,15.

<sup>188</sup> Venedikov 1960, 99-109.

<sup>189</sup> Miniero 1987, 171.

<sup>190</sup> Visy 1993, 326-327.

<sup>191</sup> *Ib.*, 282, Taf. 436: F 138.

<sup>192</sup> Bitenc, Knific 2001a, 32-33 št. 87: 29,38.

glede na to različno interpretirana kot gradbeni material, deli pohištva, ognjila, pripomočki za brušenje nožev oziroma kot predmeti, katerih način uporabe ni povsem znan.<sup>193</sup>

*Železen predmet koničaste oblike* (*sl. 18*) med pregledanim rimskodobnim gradivom nima popolne primerjave, spominja pa na pušične osti s trnom in konico kvadratnega preseka, ki znotraj rimske cesarske dobe niso natančneje datirane.<sup>194</sup>

### POSKUS REKONSTRUKCIJE ZAKLADNE NAJDBE

(*t. 1-4*)

Predstavljeni sklop najdb z Vodice že na prvi pogled ne predstavlja sklenjene celote, saj so vmes tudi srednje- ali novoveški predmeti. Del najdb pa po sicer nezanesljivih podatkih hranitelja zbirke J. J. Švajncerja skoraj gotovo sestavlja zakladno najdbo orodja iz poznorimskega časa. Kateri predmeti so sestavljali zakladno najdbo, ni več znano. Timoteju Knificu iz Narodnega muzeja Slovenije se zdi najverjetnejša celota sklop najdb,<sup>195</sup> ki mu jih je hranitelj ob prvem pogovoru predstavil kot zakladno najdbo. Poleg orodij je sklop vseboval nakovalo in tehtnico; orožja in obuval kopit ni bilo med njimi. V seznamu zakladnih najdb orodja v Sloveniji je kot vsebina najdbe z Vodice sicer naštetih nekaj manj predmetov (dve tesli, dvostrano teslo, kopača, štiri sekire, rezilo za obdelavo lesa, nož), vendar ta podatek ni zanesljivejši, saj prav tako izvira od hranitelja najdb.<sup>196</sup>

Natančnejši in verjetno zanesljivejši podatki o mestu in okoliščinah najdbe obstajajo le za meč (*sl. 3: 1*) in ob njem v prvotni legi najdena dela nožnice - zaključek nožnice (*sl. 3: 2; 4; 5*) in zanka za obešanje (*kat. št. 3*).<sup>197</sup> Predmeti so ležali v zemlji v skalni razpoki na majhni vzpetini oziroma terasi južno od travnikov Vodice desno od ceste, ko se začne vzpenjati z Vodice proti Lanišču (to je na robu antičnega naselja). Meč z deloma nožnice je bil najden sam, med okoliškimi skalami pa več železnih podkev, ostroga in rimski bronasti novci. Malo više od mesta najdbe meča je bilo najdenih "več železnih sekir ... in nekaj drugih predmetov". Omemba, ki se najverjetneje (sekire!) nanaša prav na zakladno najdbo, dokazuje, da meč ni bil njen sestavni del.

Na podlagi opredelitve najdb lahko zaradi datacije v mlajši čas iz sestava zakladne najdbe že takoj izključimo podkvi (*sl. 16*) in verjetno sulično ost (*sl. 8: 4*) in kladivo (*sl. 12: 25*). Glede na predstavljene podatke je treba izključiti še obuvala kopit (*sl. 14; 15*) in orožje (meč z deloma nožnice [*sl. 3-5; kat. št. 3*], sulična ost [*sl. 8: 5*], ost [*sl. 8: 6*], plumbati [*sl. 9*]). Orožje se tudi sicer v tovrstnih zakladnih najdbah v Sloveniji<sup>198</sup> pojavlja izjemoma, in to drugačne narave (na primer meč in sulična

<sup>193</sup> Pregledno o tovrstnih šilih, z literaturo, Klasinc 1999, 76-78, 24 št. 29, t. 4: 29; Murgelj 2000, 65-67, t. 12: 3,4.

<sup>194</sup> Radman-Livaja 2004, 56, 128 št. 64-68, t. 17: 64-68, z literaturo.

<sup>195</sup> Za podatke o verjetnem sestavu zakladne najdbe in nezanesljivosti podatkov o njej se zahvaljujem dr. Timoteju Knificu, ki se je o predmetih z Vodice večkrat pogovarjal z njihovim hraniteljem, Janezom J. Švajncerjem, ter si jih sposodil za dokumentiranje in strokovno obdelavo v Narodnem muzeju Slovenije.

<sup>196</sup> Gaspari et al. 2000, 187.

<sup>197</sup> Švajncer 2003.

<sup>198</sup> Seznam zakladnih najdb orodja v Sloveniji z literaturo pri Gaspari et al. 2000, 187-188, fig. 1. Nekatere, takrat še neobjavljene, in nekatere že objavljene so bile pozneje predstavljene v katalogu razstave Bitenc, Knific 2001, št. 14, 15, 87, 116, 117, 118, 140, 167, 168. Dopolnjen seznam zakladnih najdb, z novimi najdbami in objavami, v Božič 2005, 356-357.

ost vzhodnega izvora v zakladni najdbi z Limberka nad Veliko Račno).<sup>199</sup> Obuvala kopit za zdaj iz zakladnih najdb s slovenskega ozemlja niso znana, prisotna pa so v nekaterih zakladnih najdbah drugod, vendar ne pripadajo tipu 1.<sup>200</sup> Kateri noži (*sl. 10*), če sploh, so bili del zakladne najdbe, ni mogoče ugotoviti. Navadni noži v zakladnih najdbah železnega orodja iz Slovenije niso znani, zato jih tudi iz sestava zakladne najdbe z Vodic lahko z neko verjetnostjo izločimo. Precej vprašljiva oziroma malo verjetna je tudi pripadnost koničastega predmeta (*sl. 18*) zakladni najdbi, saj gre morda za orožje in nima primerjav v zakladnih najdbah orodij.

Kot domnevni sestavni deli zakladne najdbe z Vodic (*t. 1-4*) tako ostanejo tehtnica (*t. 1: 15; sl. 11*), tri bradve (*t. 2: 16-18*), sekiri (*t. 2: 19,20*), tesli (*t. 3: 21,22*), dvostrano teslo (*t. 3: 23*), kopača (*t. 3: 24*), rezilo za obdelavo lesa (*t. 3: 28*), sveder (*t. 3: 29*), šestilo (*t. 4: 30*), nakovalo (*t. 4: 31*), sornik (*t. 4: 39*) in šilo (*t. 4: 40*). Bradve,<sup>201</sup> sekire, tesla,<sup>202</sup> kopače, rezila za obdelavo lesa, žličasti svedri, šestila, sorniki, šila<sup>203</sup> in tehtnice so bolj ali manj običajni sestavni deli poznorimskih zakladnih najdb orodij s slovenskih najdišč.<sup>204</sup> Nakovalo v zakladni najdbi orodja ne preseneča, čeprav drugega kovaškega orodja ni v njej in čeprav so nakovala za zdaj v tovrstnih najdbah skoraj popolna izjema.<sup>205</sup> Ker pa gre za tip nakovala, ki se je pojavil že zelo zgodaj, v 1. st., ostaja dvom, ali je bilo nakovalo z Vodic res v obravnavani poznorimski zakladni najdbi.

Zakladna najdba z Vodic v zgoraj opisanem domnevnem sestavu vsebuje tipe predmetov, ki se v daljšem časovnem obdobju oblikovno niso dosti spreminjali (razen tehtnic) in jih je zato le na podlagi oblike težko ožje časovno opredeliti. Kopače, šestila in sornika znotraj rimske cesarske dobe ni mogoče natančneje datirati, tip nakovala je znan že iz 1. st., ni pa znano, kako dolgo se je ohranil, tip tehtnice je hipotetično datiran v 3. st., naknadna popravila pa kažejo na uporabo še v 4. st., sekiri se uvrščata v čas od 3. do 6. st., bradve v 3. in morda 4. st., rezilo za obdelavo lesa v čas od 3. do začetka 5. st., tesli, dvostrano teslo in sveder so poznorimski (4. in večji del 5. st.), šilo bi bilo lahko poznoantično (4. do 6. st.). Če na podlagi drugih podatkov o najdišču (najdbe ne presegajo konca 4. st.) sklepamo, da so predmeti rimski in izključimo možnost datacije nekaterih predmetov (sekiri, šilo) v mlajši del pozne antike (konec 5. in 6. st.), so najmlajši na podlagi oblike časovno določljivi predmeti poznorimski (tesli, dvostrano teslo, sveder). Zakop zakladne najdbe tako lahko datiramo domnevno v 4. st., glede na tehtnico morda na konec 4. st.

Drugi predstavljeni rimskodobni predmeti z Vodic, ki ne sodijo v domnevni sestav zakladne najdbe, so datirani podobno - ali le široko v rimsko cesarsko dobo (noži [*sl. 10*], obuvala kopit [*sl. 14; 15*], koničast predmet [*sl. 18*]), ali nekoliko ožje v čas od 3. do 5. st. (meč z deloma nožnice [*sl. 3-5; kat. št. 3*] v 3. st., sulična ost [*sl. 8: 5*] v 3. in 4. st., ost [*sl. 8: 6*] v 4. in večji del 5. st., plumbati [*sl. 9*] v 4. in 5. st.). Najdbe po eni strani osvetljujejo podobo naselja, povezanega s cestno povezavo čez Hrušico in po njej potekajočim prometom (najdbe delov voza, oprave tovornih živali in orodja), po drugi strani (najdbe orožja) pa kažejo na vključenost naselja v poznorimski zaporni sistem *Claustra Alpium Iuliarum* z eno od dveh glavnih vojaških utrdb prav na bližnji Hrušici (*Ad Pirum*).

### Zahvala

Članek je nekoliko predelano in dopolnjeno poglavje moje doktorske disertacije, ki je nastajala v letih od 2000 do 2004 v Narodnem muzeju Slovenije v okviru usposabljanja mlade raziskovalke, financiranega s strani takratnega Ministrstva za šolstvo, znanost in šport RS. Zahvaljujem se dr. Timoteju Knificu (Narodni muzej Slovenije), da mi je omogočil obdelavo sposojenega gradiva z Vodic in mi bil v praktično in strokovno pomoč. Za pogovor o najdbah, izčrpane pripombe k besedilu in napotke glede literature, zlati v zvezi s plumbatami, bradvami, dvostranimi tesli, kopačami z rogljema in nakovali, se zahvaljujem dr. Draganu Božiču (Inštitut za arheologijo ZRC SAZU, Ljubljana). Risbe predmetov so v svinčniku izdelali Ida Murgelj iz Narodnega muzeja Slovenije (4, 10-12, 31, 37-39), zunanji sodelavec NMS Uroš Stiškovski (1, 5-9, 13, 14, 16-30, 32-36, 40, 41) in Dragica Knific Lunder z Inštituta za arheologijo (3, 15), ki je tudi vse risbe v tušu pripravila za objavo. Table je oblikoval Drago Valoh (Inštitut za arheologijo), zemljevid Roman Hribar (Narodni muzej Slovenije) in Drago Valoh, angleško besedilo sta pregledala dr. Matej Accetto in dr. Agnes Pisanski Peterlin. Vsem se zahvaljujem za njihov prispevek in pomoč. Priprava besedila članka je bila končana spomladi leta 2006.

Veronika Pflaum  
Vodovodna cesta 38c  
SI-1000 Ljubljana  
veronika.pflaum@gmail.com

<sup>199</sup> Bitenc, Knific 2001a; o meču Pflaum 2000, 24 št. 97, 137-140, sl. 15, t. 15: 97.

<sup>200</sup> Seznam poznorimskih zakladnih najdb, ki vsebujejo obuvala kopit, pri Groh, Sedlmayer 2006, 518.

<sup>201</sup> Seznam bradev v poznorimskih zakladnih najdbah orodja iz Slovenije v Božič 2005, 313. Vse imajo podaljšano čelo, torej se oblikovno razlikujejo od bradev z Vodic.

<sup>202</sup> Dvostrano teslo v zakladnih najdbah iz Slovenije nima primerjave.

<sup>203</sup> Na primer Celje (Gaspari et al. 2000, fig. 7: 8).

<sup>204</sup> Gl. zgoraj opredelitve posameznih predmetov.

<sup>205</sup> V zakladnih najdbah iz Slovenije ni nakoval. Drugod je bilo blokovno nakovalo drugačne oblike najdeno na primer v zakladni najdbi iz Boljetina v Srbiji, datirani v 4. st. (Popović 1988, 146-147, t. 29: 5).

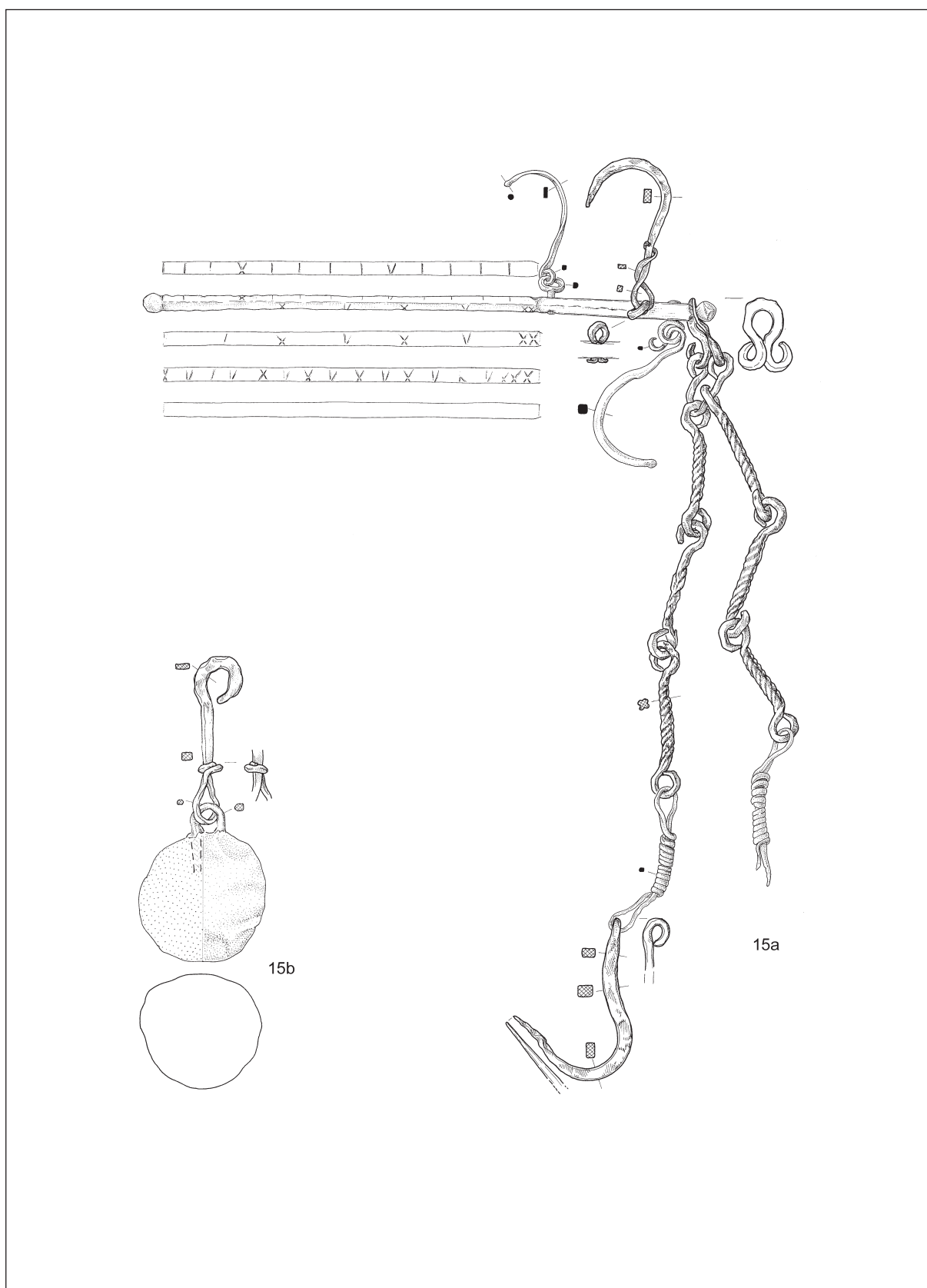

Pl. I: Vodice near Kalce, the supposed hoard. Steelyard (15) (Fig. II). Bronze, iron. Scale = 1:3.  
 T. I: Vodice pri Kalcah, domnevna zakladna najdba. Tehnica (15) (sl. II). Bron, železo. M. = 1:3.



*Pl. 2:* Vodice near Kalce, the supposed hoard. Wide axes (16-18) and axes (19, 20). 16,19,20 iron, wood, 17,18 iron. Scale = 1:3.  
*T. 2:* Vodice pri Kalcah, domnevna zakladna najdba. Bradve (16-18) in sekiri (19, 20). 16,19,20 železo, les, 17,18 železo. M. = 1:3.

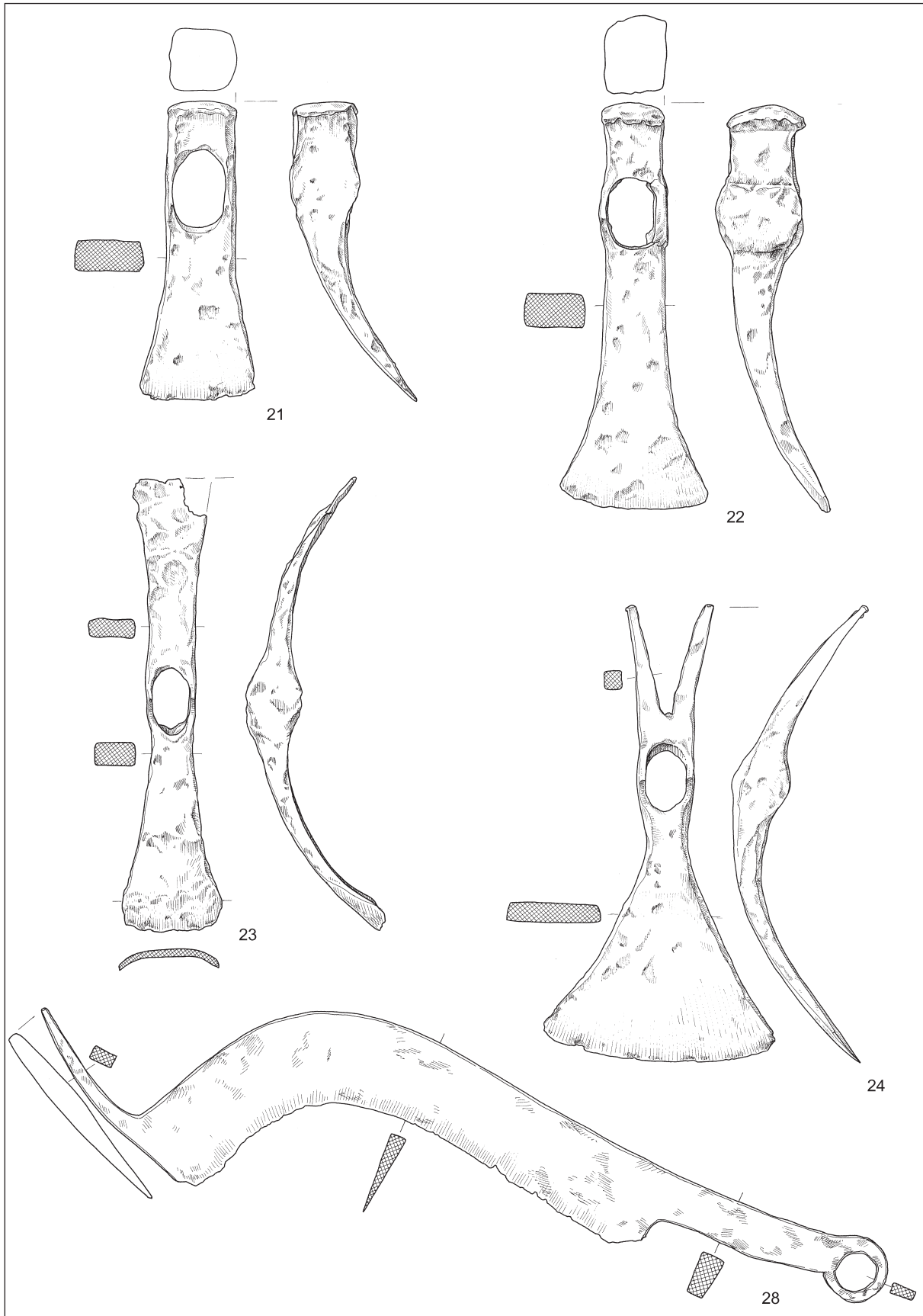

Pl. 3: Vodice near Kalce, the supposed hoard. Adzes (21-23), hoe (24) and woodworking knife (28). Iron. Scale = 1:3.

T. 3: Vodice pri Kalcah, domnevna zakladna najdba. Tesla (21-23), kopača (24) in rezilo za izdelavo lesenih predmetov (28). Železo. M. = 1:3.

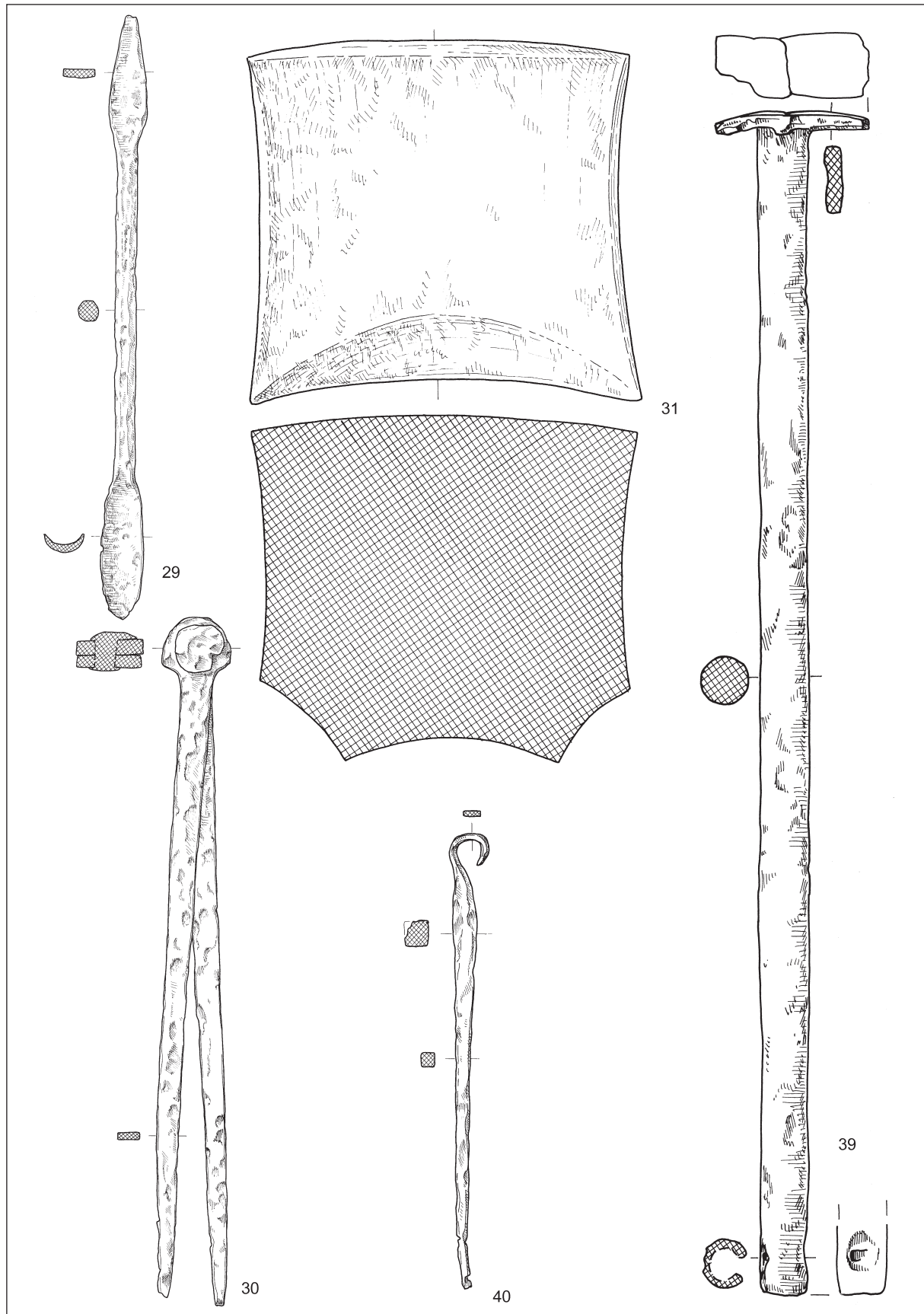

Pl. 4: Vodice near Kalce, the supposed hoard. Gimlet (29), pair of compasses (30), anvil (31) (Fig. 13), bolt (39) and awl (40). Iron. Scale 40 = 1:2; others = 1:3.

T. 4: Vodice pri Kalcah, domnevna zakladna najdba. Sveder (29), šestilo (30), nakovalo (31) (sl. 13), sornik (39) in šilo (40). Železo. M. 40 = 1:2; drugo = 1:3.